

HE-02 Ecology-E

Electrostatic Precipitator with Automatic Cleaning



- New Generation ESP designed for dependable operation
- Reliable high frequency electronics do not use fragile ionizing wires or insulators.
- Specified efficiency is instant and constant. Pressure drop is low and constant, resulting in reduced fan horsepower.
- Constant airflow prevents fluctuations in system air volume.
- Permanent aluminum collector cells never need replacing.
- Built-in automatic cleaning and PLC controls.

Ecology-E is a factory packaged kitchen exhaust system that uses electrostatic collectors to remove smoke and grease particulate and bonded carbon panels to remove odor molecules. Treatment of kitchen exhaust air has never been more critical in order that neighboring businesses can coexist. One piece compact construction assures system integrity and reduces installation cost. And, Ecology-E is available in indoor or outdoor construction, both in convenient side access housings.

The System Control is programmed to start and stop the system according to customer requirements. At a predetermined schedule, the Control also initiates a water/detergent wash cycle to clean away collected contaminants. Spent wash water is drained from the bottom drain pan, Ecology-E is forced dried and ready to continue operations. Start, stop and wash functions can also be initiated by manual push button.

NOTE: Factory must be advised of any special requirements of the Authority Having Jurisdiction at time of quote.



Conforms to ANSUL/UL STD 867 &
UL STD 710 for Electrostatic Air Cleaners

Specification

The system shall be a Halton Ecology-E, furnished as a single, factory assembled unit, consisting of: inlet transition, electrostatic precipitator, safety filter section, odor control section, outlet transition and blower/motor, all factory mounted on a 6" x 10.5 lb/ft structural steel support base with lifting lugs. The system is sized to deliver a minimum particulate removal efficiency of 95% at specified air volume, per DOP test method (MIL-STD-282). The unit shall be furnished in a single, side access housing fabricated from 14-gage steel, continuous welded pretreated and powder coated with thermo-set powder paint, inside and outside. Double wall side access doors shall be provided to service all internal components. The access doors shall be on lift-off hinges, gasketed and use threaded latches. Precipitator section access door electrical interlock shall be factory installed. The precipitator housing bottom shall be sloped to form a no-leak basin to drain wash water and furnished with a 3" FNPT drain nipple. The precipitator shall conform to the following.

UL 867; Safety Standard for Electrostatic Precipitators
ANSI/UL 710; Exhaust Hoods for Commercial Cooking Equipment

Ionizer-Collector Cells

Ionizing-collecting cells shall be of industrial design integrity and single unit construction. The cells shall be all aluminum construction except the ionizing electrode shall be of the rigid stainless steel type. Repelling and collecting plates shall be positively retained in place using tie rod and tubular spacer design. High voltage insulators shall be molded from structural, self-glazing ceramic; shall be of radial and bilateral symmetry; and shall contain no high voltage penetrations.

Built-in Cleaning System

Detergent, wash and rinse water shall be applied by oscillating copper manifolds containing brass spray nozzles, located on both the air entering and air leaving side of each cell tier. Complete, effective washing of all ionizing-collector cell surfaces and all appurtenances shall be provided. Drive motors, used to oscillate the manifolds, shall be high torque, gear reduced, totally enclosed fan cooled type, and be permanently lubricated. Drive linkage shall be the rigid, mechanical type without tracks or sprockets. A detergent dispenser assembly shall be provided and shall consist of a 55 gallon anti-corrosive reservoir, positive displacement pump, motor, and flow volume control valve. Solenoid valve, strainer, backflow preventer, ball valve, pressure gage and an initial supply of detergent shall be furnished.

System Control & Power Pack

The System Control shall be the programmable logic, PLC type, furnished in a NEMA 3R enclosure. The Control shall be factory programmed for system start/stop times and wash cycle initiation times. Operation shall be completely automatic, shall compensate for DST change and contain full battery backup. The face panel shall contain LED's for operational status and an operator interface screen that displays real-time status.

The Power Pack shall be the solid state, pulse type, operate on a single phase electrical input and provide an adjustable dual kVdc output. Input and output circuits shall be internally regulated and the output shall have a current limiting, shutdown and re-start feature. The face panel shall contain: safety interlock switch; on/off switch; input/output LED's; digital kVdc/mA readout meter.

Odor Control

Rigid, bonded, activated carbon panels shall be furnished to remove both base and acid odor molecules. Carbon mass shall be applied at a minimum of 100 lbs. per 1,000 cfm of exhaust air volume. Panels shall be held in place by gasketed, extruded aluminum tracks arranged in a v-bank configuration.

In addition to the ESP, carbon panels shall be further protected from smoke and grease particle contamination by a 95% efficient Safety Filter located between the ESP and Carbon Section. The Safety Filter shall be applied at a minimum rate of 49 ft.² media surface area per 1,000 cfm of exhaust air volume.

System Exhaust Blower

The blower shall be the SWSI or inline (specify) belt drive type with backward inclined centrifugal wheel custom selected to perform to the project specifications. Blower shall be UL 762 listed. NEMA 3R motor starter shall be furnished.

Commissioning On Site

The Ecology-E System shall be commissioned by a factory authorized engineer and a written confirmation shall be delivered to the project consultant or owner.

Side Elevation

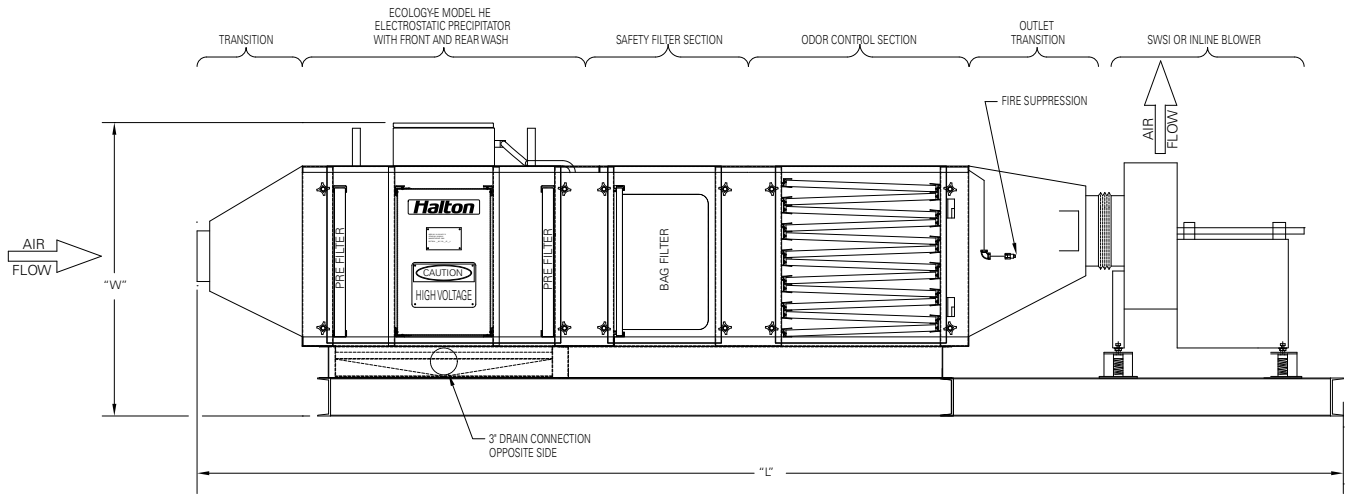

HE-02/PC/xxx1009/EN

Inlet Air Entering Elevation

Model HE-0202-W

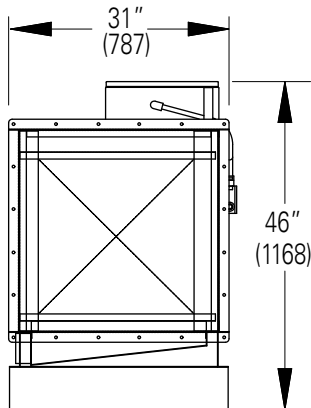

Model - HE-0202-W

| | |
|------------------|-----------|
| Air Volume (cfm) | 1,250 |
| Width (in)/(mm) | 31"/787 |
| Height (in)/(mm) | 46"/1168 |
| Length (in)/(mm) | 184"/4674 |
| Water (gpm) | 4.8 |
| Detergent (gal) | 0.48 |
| Weight (lbs) | 2,700 |

Model HE-0203-W

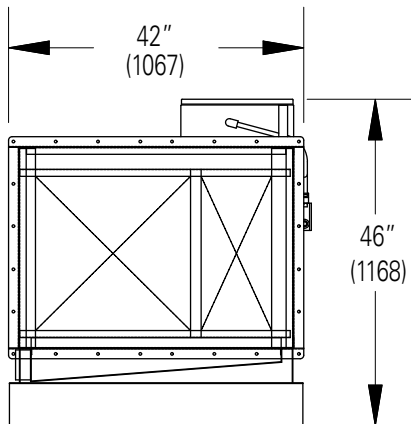

Model - HE-0203-W

| | |
|------------------|-----------|
| Air Volume (cfm) | 2,000 |
| Width (in)/(mm) | 42"/1067 |
| Height (in)/(mm) | 46"/1168 |
| Length (in)/(mm) | 185"/4699 |
| Water (gpm) | 7.2 |
| Detergent (gal) | 0.72 |
| Weight (lbs) | 3,100 |

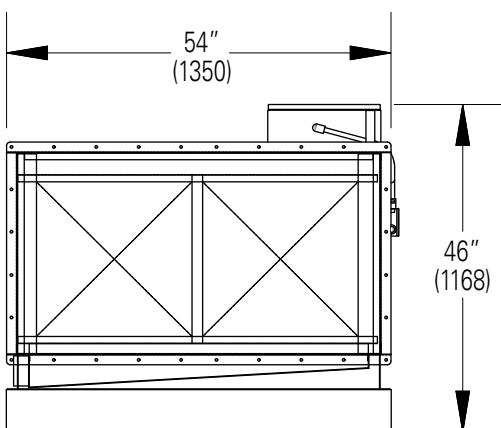
Model HE-0204-W**Model - HE-0204-W**

| | |
|------------------|-----------|
| Air Volume (cfm) | 2,500 |
| Width (in)/(mm) | 54"/1350 |
| Height (in)/(mm) | 46"/1168 |
| Length (in)/(mm) | 186"/4724 |
| Water (gpm) | 9.6 |
| Detergent (gal) | 0.96 |
| Weight (lbs) | 3,600 |

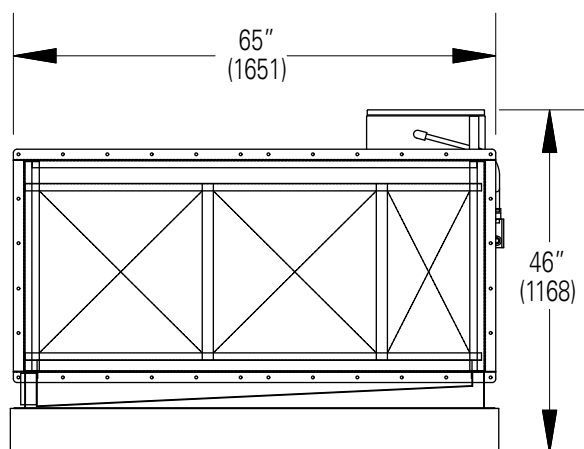
Model HE-0205-W**Model - HE-0205-W**

| | |
|------------------|-----------|
| Air Volume (cfm) | 3,500 |
| Width (in)/(mm) | 65"/1651 |
| Height (in)/(mm) | 46"/1168 |
| Length (in)/(mm) | 189"/4801 |
| Water (gpm) | 12.0 |
| Detergent (gal) | 1.20 |
| Weight (lbs) | 4,000 |

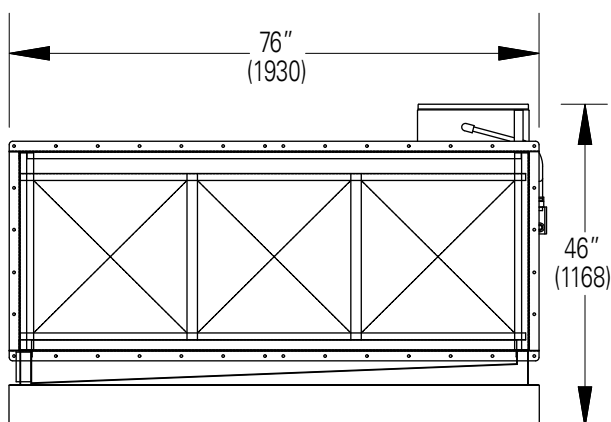
Model HE-0206-W**Model - HE-0206-W**

| | |
|------------------|-----------|
| Air Volume (cfm) | 4,000 |
| Width (in)/(mm) | 76"/1930 |
| Height (in)/(mm) | 46"/1168 |
| Length (in)/(mm) | 191"/4851 |
| Water (gpm) | 14.4 |
| Detergent (gal) | 1.44 |
| Weight (lbs) | 4,100 |