

# ABD Damper

Automated Balancing Damper

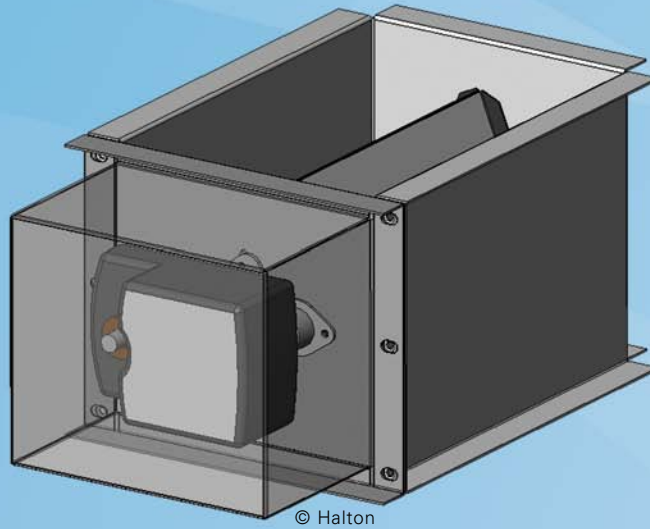

- Compact design - 8" high
- Takes direct pressure reading from Capture Jet® hood
- Used on multiple hoods with common exhaust
- Does not accumulate grease like guillotine type dampers
- Night time set back closes damper preventing air from entering the building
- Actuator fail safe opens on power interruption

## Specification

Furnish and install a Model ABD automated kitchen exhaust balancing damper as manufactured by Halton. The balancing damper shall bear the Underwriters Laboratories UL label per, UL Listed range hood accessory per standard 710 and be fabricated in compliance with NFPA-96-2004.

The installation shall be in accordance with the manufacturer's recommendations and conform to NFPA-96 guidelines and all applicable local codes. The size shall be as indicated on drawings and/or equipment schedule and match the exhaust collar size for the hood system.

The damper shall automatically adjust exhaust airflow based on direct pressure readings from integral T.A.B. test and balance port in the Capture Jet® hood. The Model ABD will have night time setback feature which will automatically close the damper when the exhaust system is shut down to prevent outside air from migrating into the space. The Model ABD will fail safe open on power interruption.

The damper outer casing shall be constructed of continuously welded 16ga. galvanized steel including the balancing blades. Optional construction is of 18ga. stainless steel. Adjustment of the parallel dampers (in open position) will be achieved by an electric motor turning the adjustment bracket until the desired pressure reading is achieved.

Note: If factory provided fire suppression, damper is provided with fire suppression piping and nozzle for duct protection above the balancing damper blades.

Model ABD is to be used on Capture Jet® style hoods, models KVE, KVC, KVL, KVM, KWW, KVR and KVO.



# MODEL: ABD

## EXHAUST VOLUME DAMPER

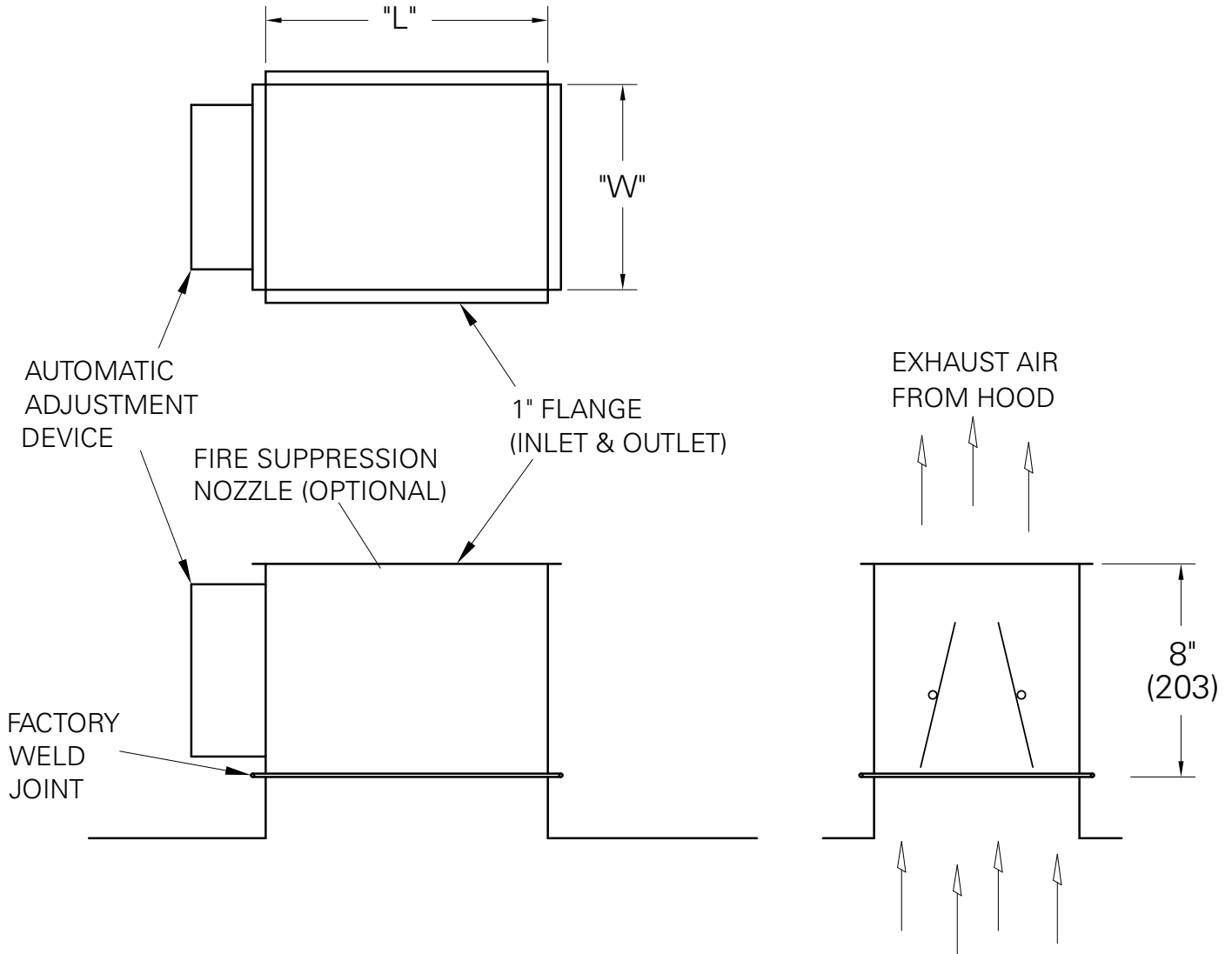

TAG	"L"	"W"	QUANTITY	INNER	OUTER
H-1	14"	12"	1	304 S.S.	GALV.
-	-	-	-	-	-
-	-	-	-	-	-

**NOTE:** Outer construction of damper must match the unexposed construction of the corresponding hood. Inner construction of the damper must match the exposed construction of corresponding hood.