

Operators Manual

Installation, Operations and Maintenance Instructions



M.A.R.V.E.L.

(Model-based Automated Regulation of Ventilation Exhaust Levels)

Halton

Table of Contents

M.A.R.V.E.L. System Overview	3
General Description	3
M.A.R.V.E.L. Unique Design	3
M.A.R.V.E.L. System Components	5
Overview	5
Components	6
M.A.R.V.E.L. Sequence of Operations	9
Overview	9
Sequence of Operations	9
M.A.R.V.E.L. System Installation	11
1. Mount the central control panel (for multiple units with a single fan)	11
2. Make central control panel connections (for multiple units with a single fan)	12
4. Connect VFD controller	13
5. Connect control panel (on hood) to central control panel (for multiple units with a single fan)	13
6. Check pressure transducer	13
7. Calibrate and align IRIS™ Sensor	14
9. Calibrate the Capture Jet® and exhaust air flows	14
10. Calibrate M.A.R.V.E.L. System (for multiple units with a single fan)	15
M.A.R.V.E.L. System Operation	17
M.A.R.V.E.L. System Maintenance	18
General	18
IRIS™ Sensor Cleaning	18
IRIS™ Sensor Alignment (Quarterly or as required)	18
IRIS™ Sensor Removal/Replacement	19
Temperature Sensor Removal/Replacement	20
Balancing Damper Actuator Removal/Replacement	23
Pressure Transducer Removal/Replacement	24
M.A.R.V.E.L. System Monitoring and Support	25
Types of Monitoring	25
KONTAR-Konsole™ Software	25
FAQs (Frequently Asked Questions)	27
M.A.R.V.E.L. Parts List	28
Contact List	29
Halton Limited Warranty	30

M.A.R.V.E.L. System Overview

General Description

Halton's M.A.R.V.E.L. (Model based Automated Regulation of Ventilation Exhaust Levels) system offers a **demand control ventilation** (DCV) solution. M.A.R.V.E.L. builds upon the existing Halton product line, such as the Capture Jet® technology, to deliver a product that reduces energy costs by scheduling and adjusting exhaust airflow based on hours of operation and appliance use.

Halton's M.A.R.V.E.L. delivers:

- Hood exhaust airflow adjustment depending on cooking activities
- Control of common exhaust fan for minimum energy consumption at all times
- Automatic or on schedule start/ stops
- Automatic balancing dampers
- Early fire warning signals
- Internet monitoring and programming

M.A.R.V.E.L. Unique Design

Starting with the Halton extensive product line of commercial foodservice ventilation solutions, M.A.R.V.E.L. adds the following four unique components:

IRIS™ infrared temperature sensors: Used to measure the rate of change of the cooking surface temperature, the sensor acquires a "heat signature" of the equipment positioned below each sensor. The thermopile-based device is placed in the ball socket fixture in the Capture Jet® plenum. An air jet exits the plenum around the sensor to protect the optic sensor from dirt and cooking debris. The sensor can be easily moved and re-aligned as needed using the provided Laser Alignment Tool.

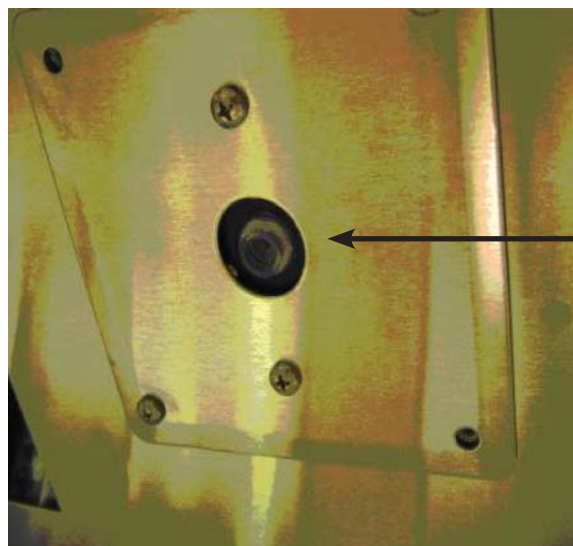

IRIS™ Sensor mounted in Capture Jet® Plenum

MC8 Controller: The heart of the system, the controller features 22 inputs/outputs and is designed to collect real time information and to implement various automation control algorithms. The MC8 Controller responds to the infrared sensor(s) and duct temperature sensor to measure changes in cooking status.

Example:

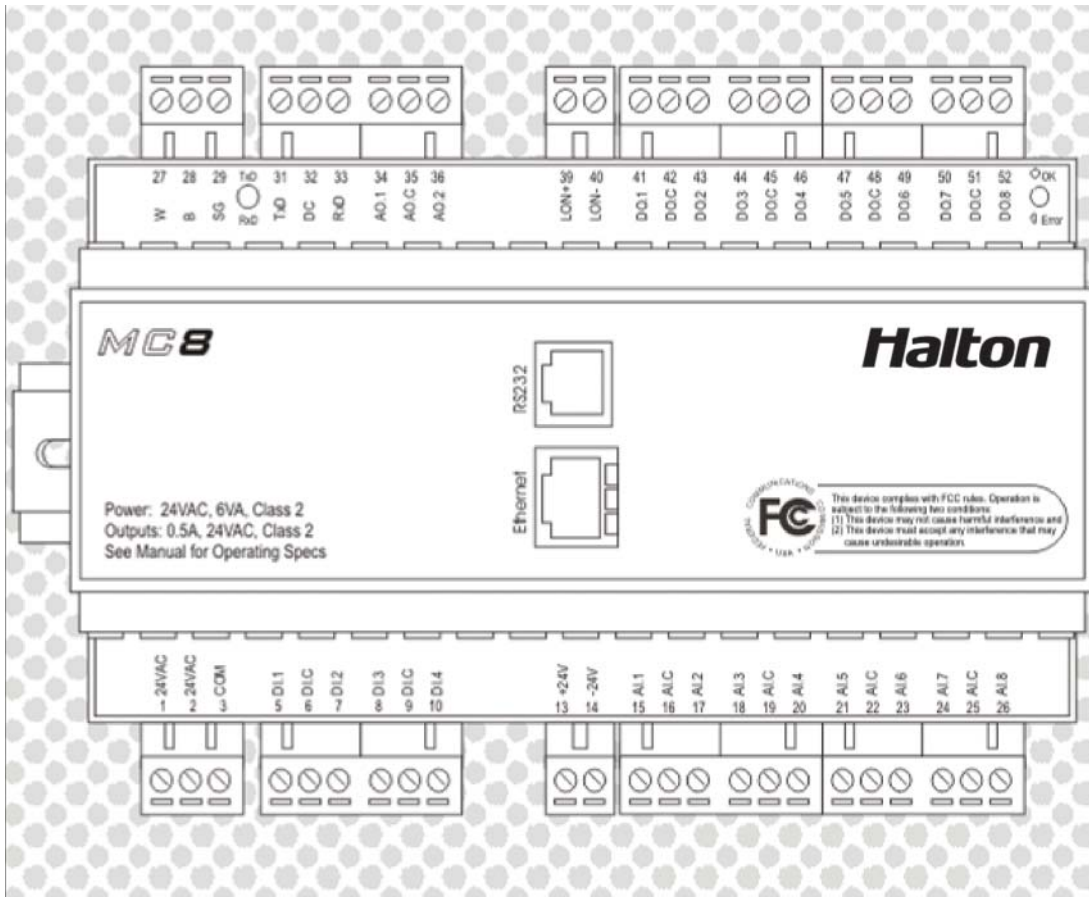

Differential Pressure Transducer: Used in conjunction with the value from the temperature sensor and IR Index to measure and control the airflow thru each hood. In addition, for multiple units with a common exhaust fan, there is an additional differential pressure transducer mounted on the common exhaust duct.

Temperature Sensor: Located in the hood collar, the temperature sensor is used in conjunction with the pressure transducer value and IR Index to control the airflow.

M.A.R.V.E.L. System Components

Overview

A key feature of the M.A.R.V.E.L. system is flexibility. It can be applied to a single hood – or over multiple hoods – depending on the requirements.



Figure 1: Single Hood M.A.R.V.E.L. Installation



Figure 2: Multiple Hood M.A.R.V.E.L. Installation

Components

NOTE: Refer to Figure 1+2

Equipment	Description	Power + Connection Details
IR1, IR2, IR3 Infrared radiation sensor (IRIS™)	<ul style="list-style-type: none"> Mount 1 to 4 IRIS™ sensors per hood depending on the length of the hood. Calculates an index which averages the temperature radiation over the sensor's field-of-view. Used to detect when one or more pieces of cooking equipment are turned on and it is necessary to start the hood fan in idle mode. Used to measure a rapid change in temperature of cooking surfaces (for example, cooking activities) and adjust the air flow in the hood to the required level. 	<p>Power source: 5 volt DC power supply located in a control panel.</p> <p>Connection: at terminal block located behind a cover on the Capture Jet® plenum.</p>
TS Duct temperature sensor	<ul style="list-style-type: none"> Measures the temperature of the exhaust air. Located in the hood collar. Used (in conjunction with the IR Index) to detect the event of cooking equipment start-up. Duct temperature is often a better indicator of start-up in the case of certain types of equipment such as a gas fryer. Used to activate the early fire detection alarm, activated before the fire system is triggered. 	<p>Connection: at terminal block located behind a cover on the Capture Jet® plenum.</p>

Equipment	Description	Power + Connection Details
PT Hood plenum pressure sensor	<ul style="list-style-type: none"> Used to calculate air flow in a hood in real time. 	<p>Power source: 24 V DC power supply located in a control panel.</p> <p>Connection: at terminal block located behind a cover on the Capture Jet® plenum.</p>
ABD Automatic balancing damper	<p>NOTE: For multiple hood installations with a single exhaust fan only</p> <ul style="list-style-type: none"> Adjusts air flow with motorized balancing dampers attached to a collar at each hood. Damper controlled by a 0-10 V DC position reference signal generated by a controller. Upon power failure, the automatic balancing damper fully opens. 	<p>Power source: 24 V AC transformer located in the control panel.</p> <p>Connection: at terminal block located behind a cover on the Capture Jet® plenum</p>
Alarm light and audible alarm/ buzzer	<ul style="list-style-type: none"> Activated when any alarm condition is detected. Common alarm conditions include: filter missing, filter clogged, fire suppression system activated, duct temperature dangerously high, sensor failed, or VFD is in fault. <p>NOTE: To easily diagnose the alarm, use the remote Konsole™ Diagnostic Software.</p>	
Override push button	<ul style="list-style-type: none"> Used to override pre programmed operation. Two modes: <ol style="list-style-type: none"> Press and hold for 1 second to accelerate the exhaust rate to 100% of the design air flow for a pre programmed period of time (default 5 minutes.) Press and hold for 3 seconds to accelerate the exhaust rate to 100% of the design air flow for a pre programmed period of time (default 1 hour.) Starts the hood if it has been overridden by a schedule or an 'off' state. 	<p>Connection: at terminal block located behind a cover on the Capture Jet® plenum.</p>
Room temperature sensor	<ul style="list-style-type: none"> Mounted on a kitchen wall close to a thermostat. 	<p>Connections: to the control panel with 2 wires</p>
VFD Variable Frequency Drive	<ul style="list-style-type: none"> Controls the speed of a three-phase fan motor by changing the frequency of the current to the motor. For smaller fans, mount the VFD in a cabinet attached to a hood. For larger exhaust fan units, attach the VFDs to a fan unit or cabinet or mount remotely. 	<p>Power source: varies as per fan's voltage requirement</p> <p>Connection: at terminal block in VFD control panel to main control panel</p> <p>Speed reference: 0-10 VDC</p>

Equipment	Description	Power + Connection Details
<p>CP</p> <p>Control Panel</p>	<ul style="list-style-type: none"> Mounted on top of each hood with access from the bottom. <p>NOTE: For multiple units with a single fan, a separate control panel (see below) is also required.</p> <ul style="list-style-type: none"> Provides permanent Ethernet connection (optional). Provides temporary Ethernet connection for service. Provides RS232 cable connection for on-site service 	<p>Power source: 120 VAC, 5 amp. fuse, grounded</p>
<p>Central control panel (for multiple units with single fan)</p>	<ul style="list-style-type: none"> Separate control panel mounted at a convenient location to link that individual control panels on the hoods with the VFD controller. 	<p>Power source: 120 VAC, 5 amp. fuse, grounded</p>

M.A.R.V.E.L. Sequence of Operations

Overview

A sequence of operations is a series of steps required to perform a given task. The DCV system uses the following sequence of operations to control the exhaust hood operation.

Sequence of Operations

Startup & Shutdown

Operation Step	Details
Startup	<ul style="list-style-type: none"> • Turns exhaust system on. • Can be started by: <ul style="list-style-type: none"> • 24/7 pre-programmed schedule. • The building management system or via an internet connection remotely. • Using a locally mounted on/off switch. • Reaching a pre-determined IR Index or duct temperature level. • Pressing the override button. • After startup, enters Idle mode.
Shutdown	<ul style="list-style-type: none"> • Turns system off. • Can be shutdown by any of the parameters listed in the Startup step (above) except the override button.
Idle Mode	<ul style="list-style-type: none"> • System starts up in Idle mode (after startup). • Pending until signs of cooking activity sensed from IRIS™ sensor(s). • Minimal exhaust flow captures any appliance-generated heat. Default is 60% of design air flow or as adjusted to meet requirements. • After idle mode, enters Active mode.
Active Mode	<ul style="list-style-type: none"> • System moves into Active mode when an IRIS™ sensor detects cooking activities under the hood. • Exhaust fan speed increased to design air flow and balancing dampers (if present) adjusts the airflow in the hood to design level to assure sufficient capture and containment. • Air flow in the hood is maintained for a predetermined cooking time before returning to the Idle mode. <p>NOTE: If during this time more cooking activities are detected, the cooking timer will be restarted.</p>
Override Mode	<ul style="list-style-type: none"> • Used to override pre programmed operation. • Two modes: <ol style="list-style-type: none"> 1. Press and hold for 1 second to accelerate the exhaust rate to 100% of the design air flow for a pre programmed period of time (default 5 minutes). 2. Press and hold for 3 seconds to accelerate the exhaust rate to 100% of the design air flow for a pre programmed period of time (default 1 hour.) Starts the hood if it has been overridden by a schedule or an 'off' state.

Operation Step	Details
Fire Mode	<ul style="list-style-type: none"> • If a fire signal is detected in the kitchen, the system triggers a fire alarm and stops the make-up air fan. • The exhaust fan will either stop or continue running depending on the local fire code requirements.
Off Mode	<ul style="list-style-type: none"> • Exhaust and make-up air fans stop when no appliances are operating (e.g., turned off and cooled down).
Airflow Reporting and Replacement Air Control	<ul style="list-style-type: none"> • System continuously monitors exhaust airflow at each hood and generates a signal 0 to 10 V proportional to total exhaust airflow as fraction of total design. 0 V - system is off; 7 V - system operates at 70% of design airflow, etc. This signal is used to control Replacement air to maintain building pressurization.
Alarm and Fault Conditions	<ul style="list-style-type: none"> • System constantly monitors various parameters. If any unusual or abnormal condition is detected, an alarm is activated. • An alarm indicator can include: <ul style="list-style-type: none"> • A local alarm light and buzzer on a control panel. • Email or text message sent to a computer or a mobile device, pager, visual display on a computer screen or through a SCADA interface.

M.A.R.V.E.L. System Installation

The following installation steps ONLY apply to the M.A.R.V.E.L. components (IRIS™ Sensor, MC8 Control Panel, Pressure Transducer and Temperature Sensor).

Refer to the Capture Jet® Hood IO&M Manual for complete details on installation of the hoods.

Refer to the Halton engineering drawings for additional details.

Refer to the Halton wiring drawings for configuration details.

Refer to the fan manufacturer's manual for detailed instructions on the fan installation.

It is the responsibility of the installing contractor to see that the system installation is completed in accordance with the project plans and specifications and that it meets all specific requirements of local code officials. The local authority having jurisdiction could over rule some of the installation details written in this manual.

The installation shall be in accordance with NFPA-96. All electrical systems shall be installed following local and national codes.

If questions or complications should arise during the installation of the Halton hood (s) that cannot be solved using the instructions provided, please contact the Halton office at 1-800-442-5866, or (1-800-4-HALTON).

If a problem cannot be correct through verbal or written communication with Halton support, the system can be connected to the Internet for remote access to Halton engineers through the KONTAR-Konsole™ Commissioning and Diagnostic Software Interface.

If the site doesn't have reasonable access to the Internet, a wireless CDMA router can be shipped by Halton to the facility for temporary (or permanent) access.

Check all local codes prior to installation as special requirements may be necessary depending on local building material construction.

1. Mount the central control panel (for multiple units with a single fan)

NOTE: For all units, there is a pre-mounted control panel on the top of the hood.

1. The central control panel is supplied with mounting tabs that extend from the back wall up and down and provide at least four points of attachment. The appropriate mounting hardware is to be used depending on the unit size and the type of wall to be attached to.
2. Locate the central control panel at an appropriate mounting height (e.g., access to the control in the front door of the panel).
3. Attach the central control panel using the four mounting holes:
 - For concrete block walls, solid block and brick surfaces: Use sleeve stud anchors (recommended).
Example: 3/8 " dia.- thread: 5/16-18; washer OD: 7/8 " (Drill size 3/8 ")
 - For Plaster, Wallboard and Plywood: Use sleeve screw anchors (drive or drill style) (recommended).

Example: 1/4" - 20 drill size 7/16"

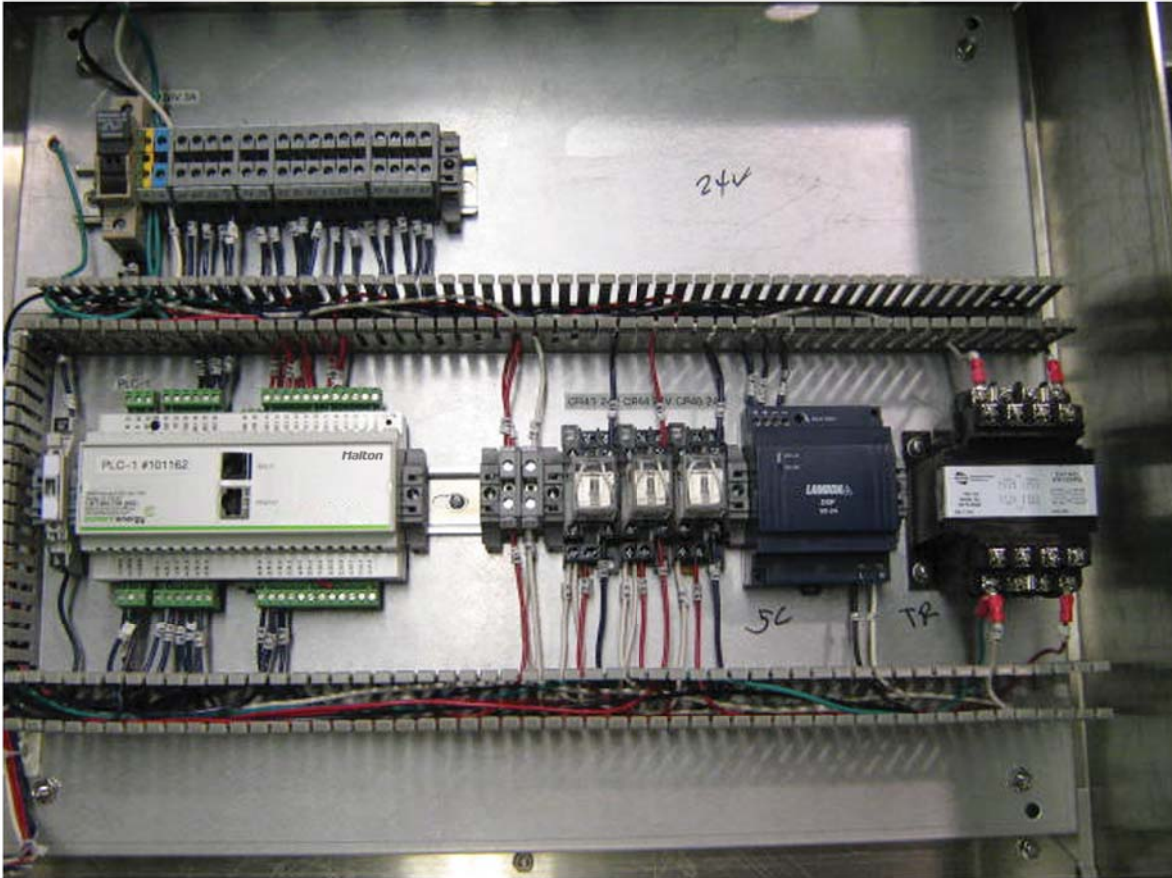

NOTE: If more than one control panel is used in a M.A.R.V.E.L. system with a single exhaust fan, connect them together to ensure that proper operation of the exhaust fan. Refer to the Halton supplied wiring diagram for details.

2. Make central control panel connections (for multiple units with a single fan)

Make the following connections at the central control panel:

- a. 120 VAC, 5 amp power to control panel.
- b. Space temperature sensor to control panel (2 wires).
- c. Pressure transducer from common duct (2 wires).
- d. VFD terminal block to control panel (6 wires shielded).
- e. Connection to individual hood (2 wires shielded) (cable provided by Halton).
- f. Connection to kitchen fire system (2 wires)
- g. Permanent Ethernet connection (if specified).
- h. UV or Water Wash control.

3. Connect VFD controller

Connect VFD controller as per instructions provided. This includes:

- a. Main power connection for the fan motor.
- b. Connection to central control panel.

4. Connect control panel (on hood) to central control panel (for multiple units with a single fan)

Using 2 wire shielded cable provided by Halton, connect each unit to the central control panel. This includes:

1. Attach the wire to the terminal block in the control panel mounted on the hood.
2. Run the wire to the central control panel and connect the marked terminal block (identified by hood number)
3. Connections can be also made between hoods with 2 wire shielded cable and connect the hood closest to the control panel to terminals in the panel.

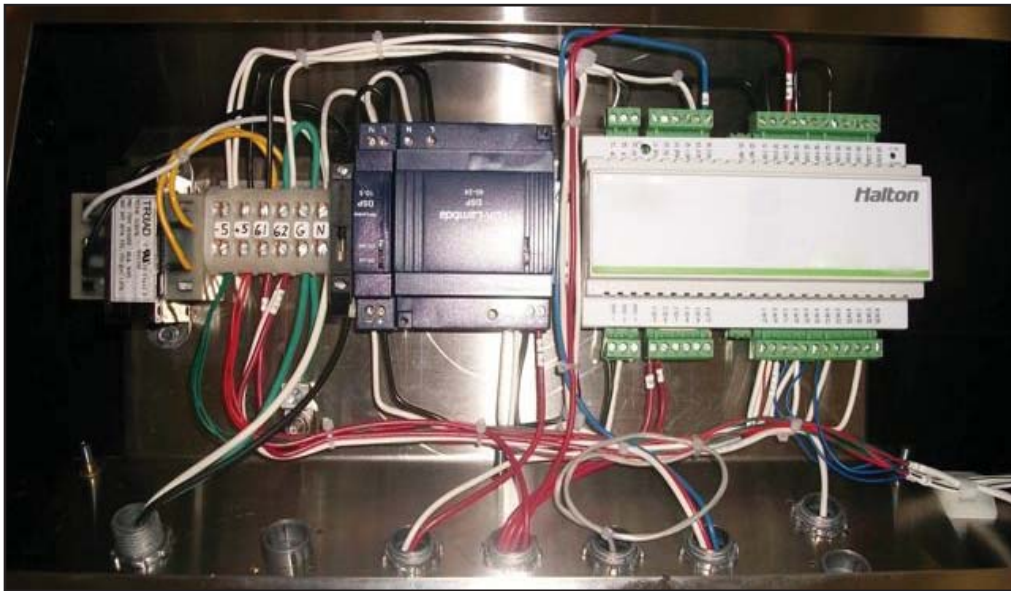

5. Check pressure transducer

1. Check the condition of the pressure transducer tubing on the top of the Capture Jet® hood. The tubing should be free from kinks.

6. Calibrate and align IRIS™ Sensor

NOTE: The IRIS™ Sensor is calibrated after installation in the hoods.

The sensor is tested using a 'black body' (does not reflect IR light) such as a sheet metal with a diameter of at least 16" (aluminum) and painted black). Always store this calibration tool away from direct sunlight and where the space temperature can be measured.

The IRIS™ sensor calibration is done in the factory. It has to be done in the field only when the sensor is replaced.

To calibrate the IRIS™ Sensor, follow these steps:

1. Install the IR sensors in the hood and terminate them.
2. Direct the IR sensors vertically down.
3. Start the control system and launch the Konsole™ software.
4. Bring the calibration tool closer to the sensor (approximately 3-5" from the sensor). The distance between the sensor and the tool should guarantee the field of view of the sensor will be completely within the black body surface.
5. Register the space temperature t (in °F).
6. Register the **IR_Temp** reading T (in °F).
7. Calculate the calibration offset: **Calib_Offset** = $t - T$
8. Assign this value in the Konsole™ screen to the appropriate parameter.
9. Check the **IR_Temp** reading. The reading should be equal to the hood's space temperature reading.
10. Align the IRIS™ sensor(s). See IRIS™ Sensor Alignment (Quarterly or as required), page 18 for details.

9. Calibrate the Capture Jet® exhaust air flows

Calibrate the Capture Jet® exhaust air flows using the T.A.B.™ (Testing and Balancing Ports).

To determine the correct T.A.B. port reading for the exhaust hoods, follow these steps:

1. Ensure that the equipment is operating to create a thermal plume prior to the air balancer.
2. Determine the correct T.A.B. port reading (IWC) based on the Capture Jet® hood model.

Capture Jet Hood Model	T.A.B. Port Readings Design T.A.B. (inches WC)
KVE/KVC	0.25
KVW	0.25
KVR	0.25
KVL	0.28

"Example Only"

3. Using the T.A.B. Port, take a reading in IWC.

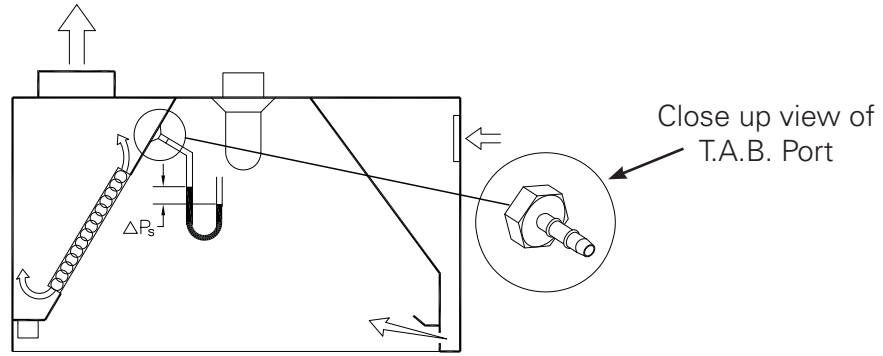

4. Using the table below, confirm the design airflow (e.g., 1700 cfm), based on the T.A.B. Reading (e.g., 0.19 IWC).

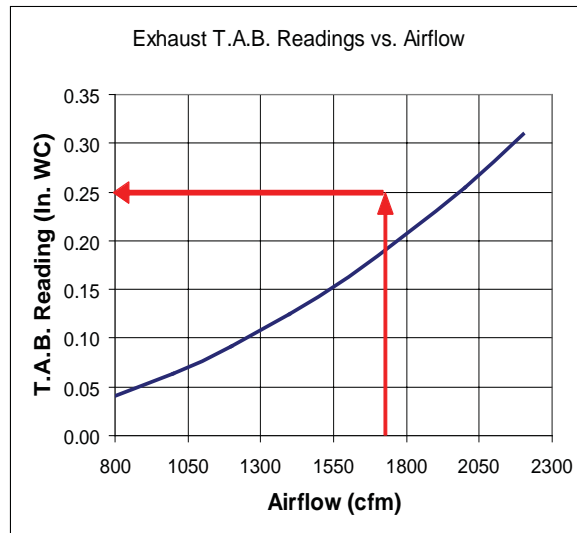

"Example Only"

10. Calibrate M.A.R.V.E.L System (for multiple units with a single fan)

NOTE: Make sure that the filters are in place prior to calibration.

To calibrate the M.A.R.V.E.L. system, follow these steps:

1. Open the Konsole™ software (see KONTAR-Konsole™ Software, page 25 for more details).

- Open the Controller (using the dropdown list) and open the I/O screen using the icon



from the toolbar. Click **Put all outputs in AUTO**.

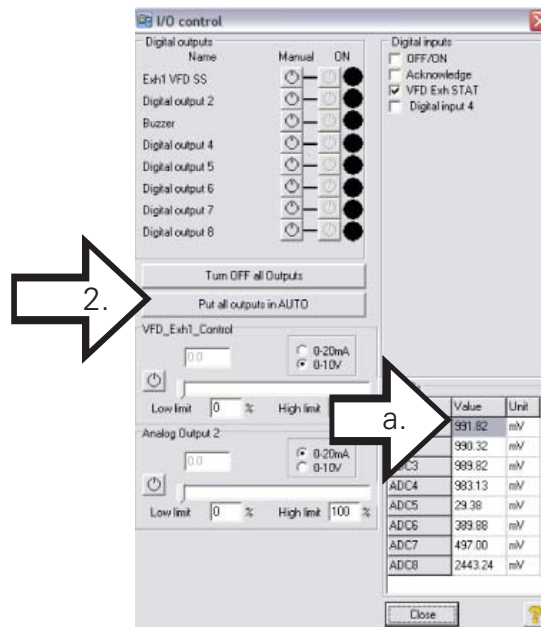

- Repeat for all controllers
- When the system is in automatic mode, select the VFD controller screen. Select the Process tab.

NOTE:

- Click **Calibrate**.

This turns on the calibrate function and the calibration process begins. During the calibration process, leave ALL settings along.

- Monitor the **Calibrate_Out** field. It starts at 100% and counts down until calibration complete (e.g., >0%)

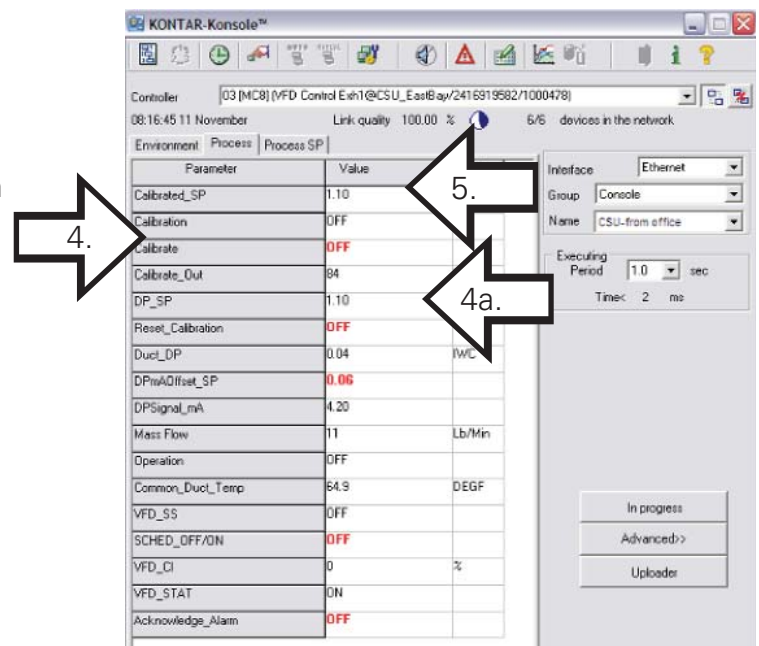

- When the calibration is completed, confirm that there is a value > 0 in the **Calibrated_SP** field.

NOTE: If calibration must be aborted, select the **Reset_Calibration** field. When ready to re-run the calibration process, return to step 4a.

M.A.R.V.E.L. System Operation

NOTE: Refer to the Capture Jet® Hood IO&M Manual for complete details on operating the hoods.

The following steps **ONLY** apply to the M.A.R.V.E.L. components (IRIS™ Sensor, MC8 Control Panel, Pressure Transducer and Temperature Sensor).

NORMAL OPERATION

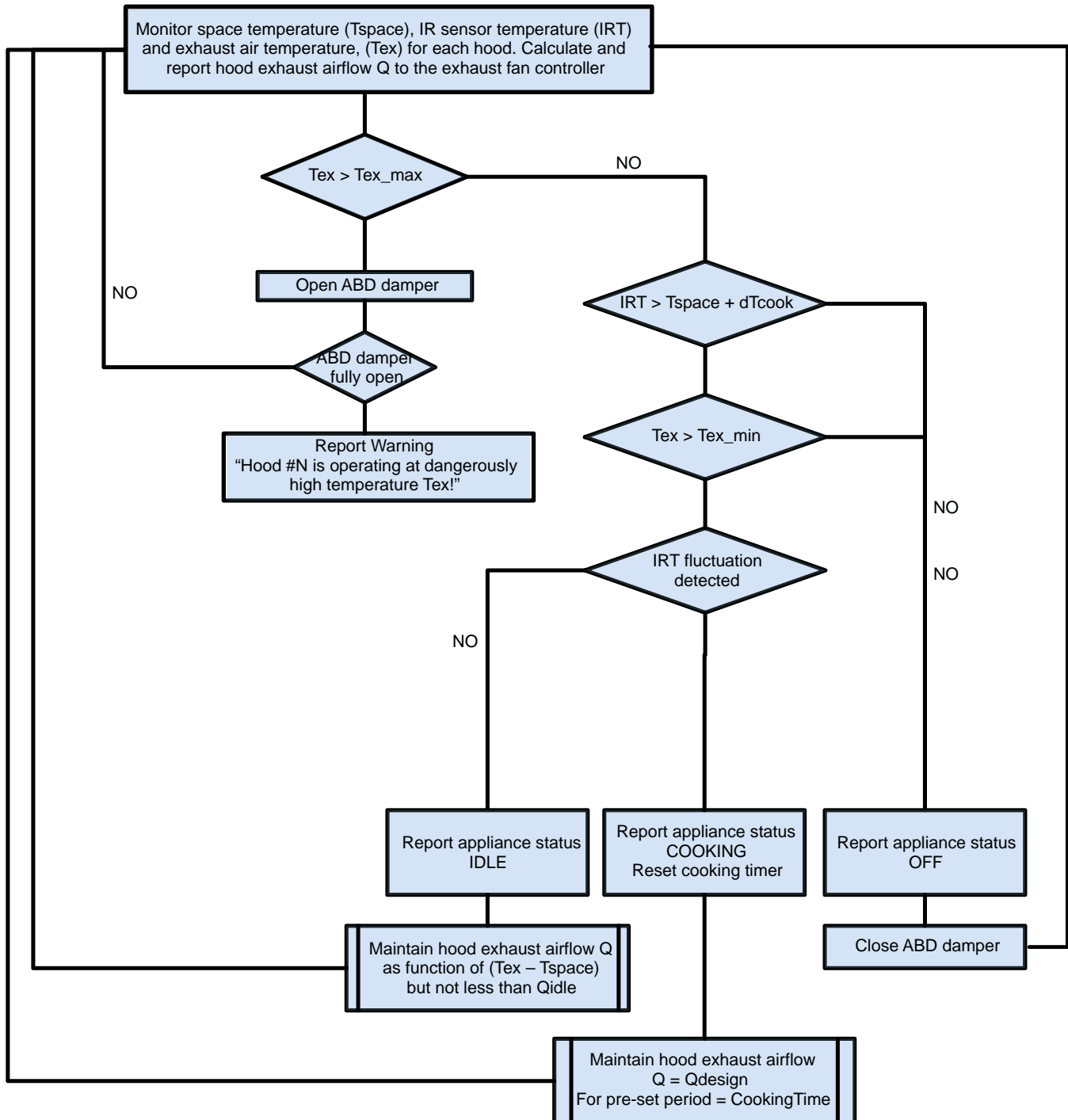

M.A.R.V.E.L. System Maintenance

General

NOTE: A preventive maintenance program is an important aspect of an effective safety program. Consult your manufacturing or other qualified consultant with question concerning changes observed during periodic inspections and routine maintenance.

Refer to the Capture Jet® Hood IO&M Manual for complete details on maintaining the hoods.

The following maintenance steps ONLY apply to the M.A.R.V.E.L. components (IRIS™ Sensor and Temperature Sensor).

IRIS™ Sensor Cleaning

NOTE: The IRIS™ Sensor is mounted on the Capture Jet® plenum door to allow an air jet to protect the sensor optics from contaminants. However, periodic cleaning may be required to keep the optics clear.

Gently clean the IRIS™ socket with isopropyl alcohol on a cotton swab (Q-tip™), as required.

Take care not to move the position of the optic; see below on how to realign the IRIS™ Sensor.

IRIS™ Sensor Alignment (Quarterly or as required)

To align the IRIS™ Sensor, follow these steps:

1. Insert the Laser Alignment Tool into the socket at the bottom of the IRIS™ sensor.

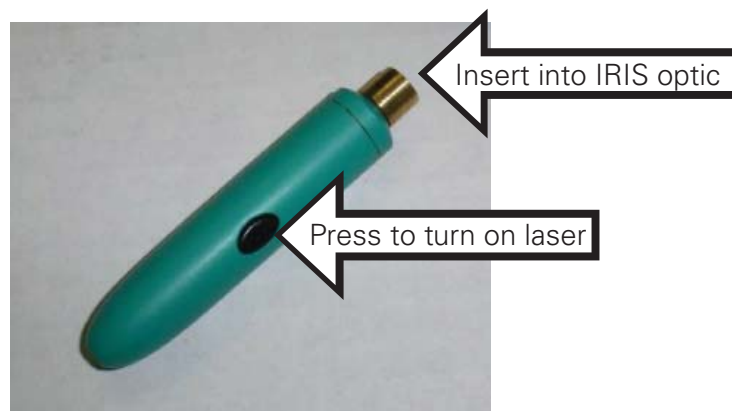

2. Press the laser button, located on the side of the *Laser Alignment Tool*.
3. Gently move the IRIS™ sensor to position the laser beam point at the center of the cooking surface. **NOTE:** The actual field of view for most applications will be 60 degrees.
4. Remove the Laser Alignment Tool.

IRIS™ Sensor Removal/Replacement

To remove the IRIS™ Sensor, follow these steps:

1. Disconnect the IRIS™ sensor from the terminal block located in the Capture Jet® hood. Refer to the terminal block diagram on the Halton-supplied wiring diagram for the correct terminations points.
2. Remove the face plate of the sensor by removing the 4 face plate screws.
3. Lift out the face plate and sensor and gently pull out the sensor wires.
4. Remove the sensor bracket from the face plate by removing the 2 screws on the faceplate.
5. Remove the sensor from the sensor bracket by removing the 3 screws.
6. Reverse the steps when replacing the IRIS™ sensor (Halton Part # 18037).

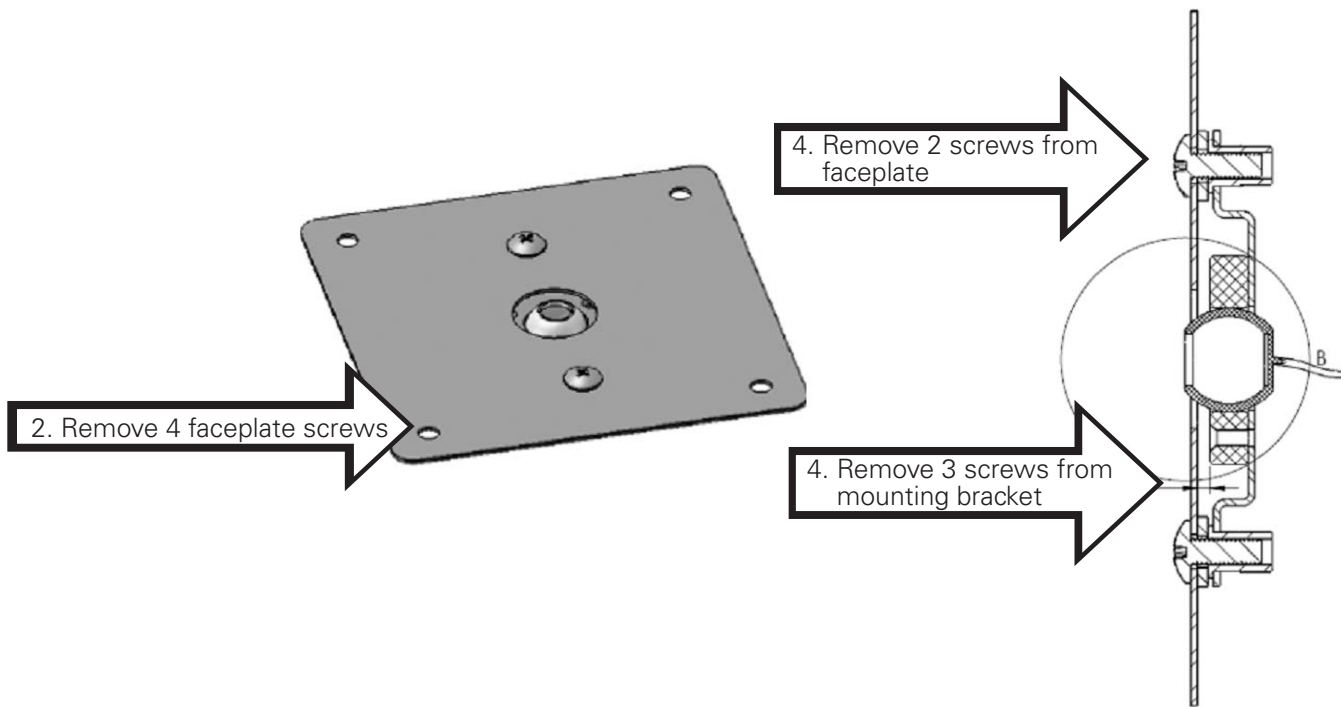

Temperature Sensor Removal/Replacement

To remove the temperature sensor located in the hood collar, follow these steps:

1. Disconnect the temperature sensor from the terminal block located in the Capture Jet® hood. Refer to the terminal block diagram on the Halton-supplied wiring diagram for the correct terminations points.
2. Unscrew the tightening collar on the temperature sensor.

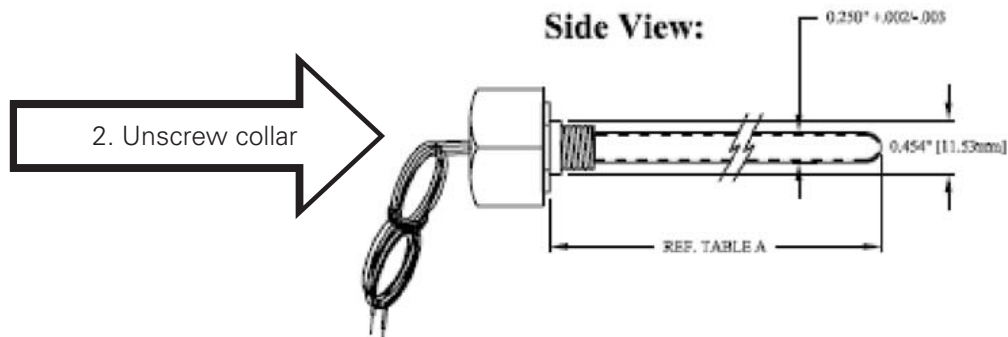

3. Remove the temperature probe.
4. Replace the defective temperature probe with a replacement (Halton Part # 17641)
5. Reconnect wiring.

Balancing Damper Actuator Removal/Replacement

To remove and replace the actuator on the balancing damper, follow these steps:

1. Remove exterior metal cover by removing the 6 mounting screws around the perimeter.
2. Remove the actuator cover by removing the 1 screw on the side.
3. Disconnect the power to the actuator.
4. Record the DIP switch values, located in the red holder on the bottom of the actuator.

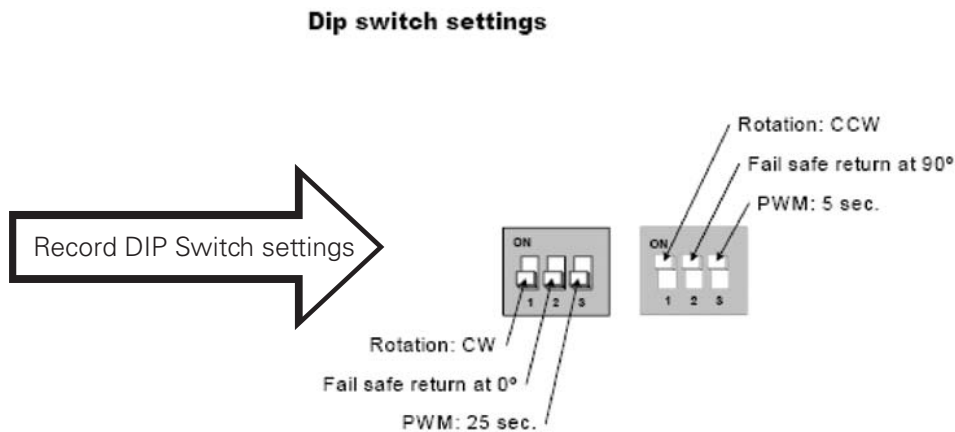

5. Note the position of the stop screws.

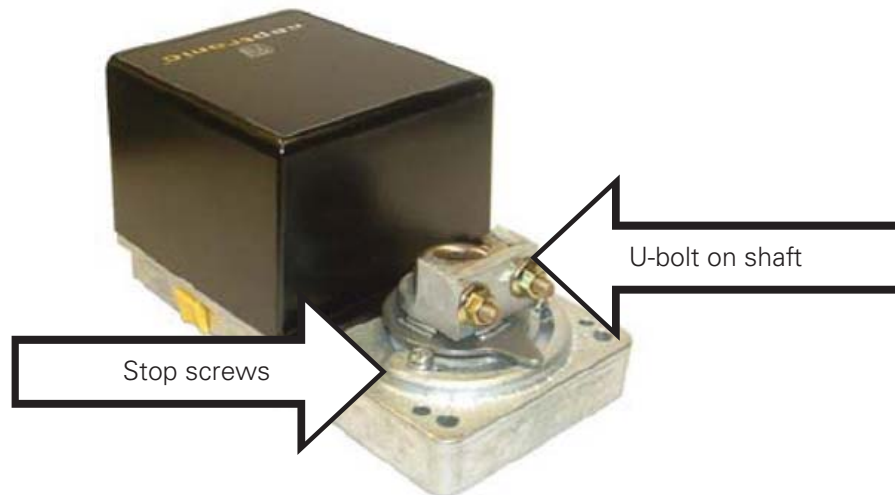

6. Remove the U-bolt that attaches the actuator to the balancing damper shaft. Refer to the Actuator Specification and Installation instructions with the replacement part.

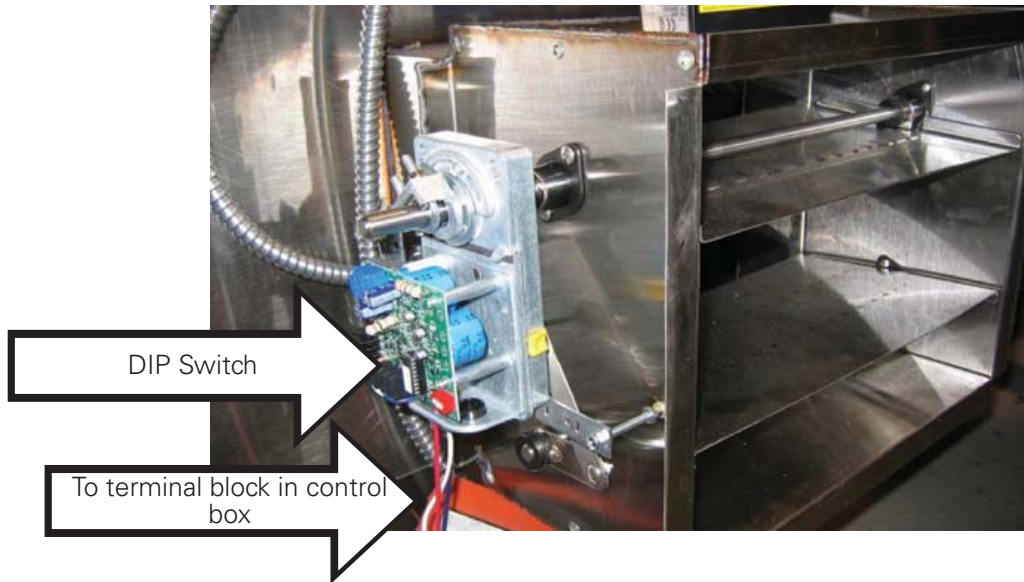

7. *Replace with a replacement actuator (Halton Part # 16012). Tighten the U-bolt on the drive shaft.*



8. *Reset the DIP switches.*
9. *Reset the stop screws.*
10. *Reconnect the power.*
11. *Calibrate the new actuator by pressing the **Reset** button. The dampers will open and close.*

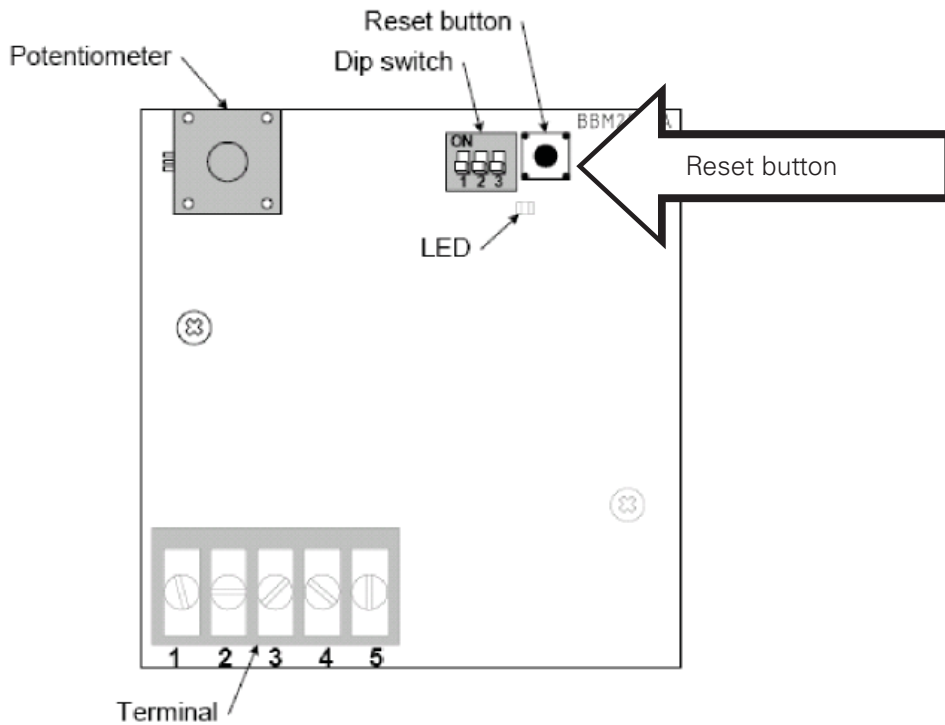

12. Replace the actuator housing and the exterior metal cover as before.

Balancing Damper Actuator Removal/Replacement

To remove the pressure transducer, follow these steps:

1. Turn off power to transducer.
2. Remove covering on pressure transducer mounting bracket.
3. Disconnect wires.
4. Disconnect ¼" aluminum tubing fitting



5. Remove pressure transducer faceplate (4 screws).
6. Remove side mount screws (2 screws).
7. Replace with Halton Part # 18028).
8. Reconnect wires and tubing as before. Check that the tubing is not kinked.

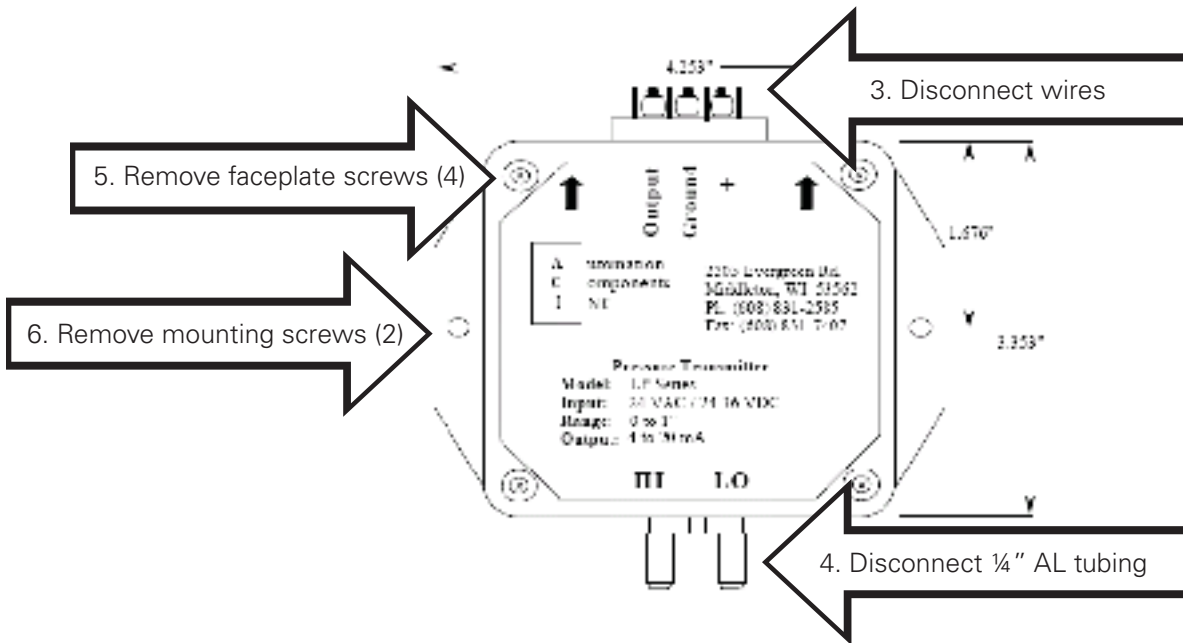

M.A.R.V.E.L. System Monitoring and Support

Types of Monitoring

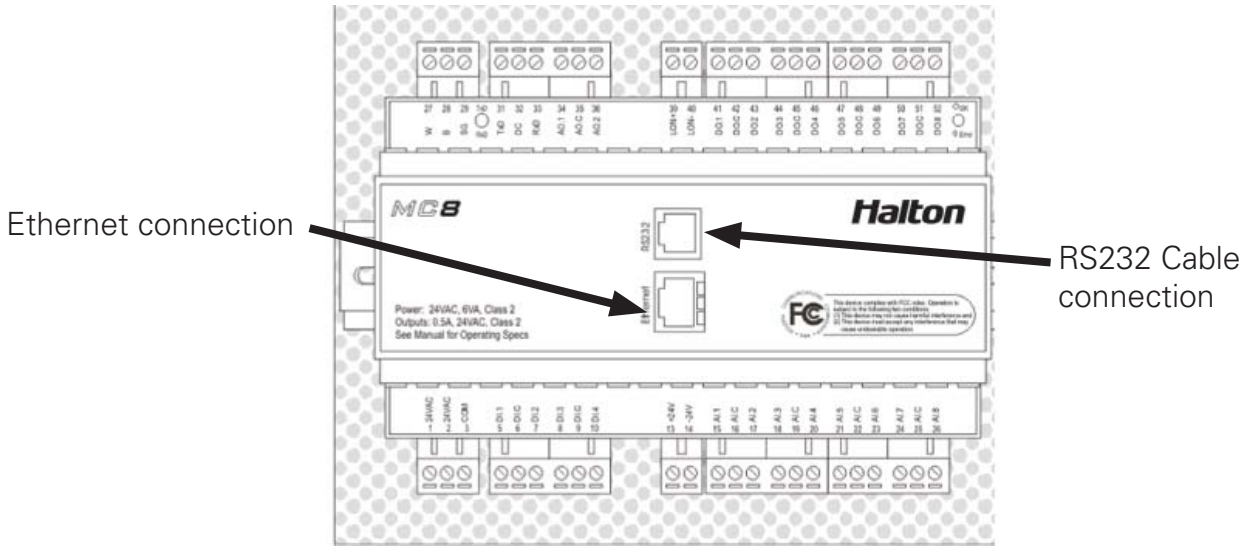

Type of Mounting	Details
Permanent Ethernet-connection for 24/7 monitoring	<ul style="list-style-type: none"> Optional. Permanent internet monitoring using SCADA graphical interface. By using a unique password and ID, user can check system status and, depending on access levels, change parameters and alarms.
Temporary Ethernet connection, as required, for support	<ul style="list-style-type: none"> Temporary Ethernet connection for startup/troubleshooting by Halton Technical Support only
Temporary cable to laptop connection, as required, for support	<ul style="list-style-type: none"> RS232 cable connection to laptop pre loaded with KONSOLE™ software for diagnostic support.

KONTAR-Konsole™ Software

The KONTAR-Konsole™ Commissioning and Diagnostic Software Interface displays set operating parameters and actual values. When accessed and reviewed by a trained Halton technician, support and troubleshooting can be offered.

NOTE: Only Halton- trained technicians should access this software.

For additional details and support with KONTAR-Konsole™ software, use the on-line help from the toolbar.



For example:

The screenshot shows the KONTAR-Konsole™ interface. At the top, it displays 'Controller: 0001 M * [MCB] (Single Hood/2415921988/2884)' and '09:58:12 07 February 2008'. Below this is a 'Process' tab and a 'Settings' tab. The main area contains a table of parameters and their values. On the right, there are settings for the 'Interface' (Ethernet), 'Group', 'Name' (Office Local), and 'Executing Period' (0.1 sec). At the bottom, there are status indicators for IP, time, and version.

Parameter	Value	Unit
IR1_Cooking_Signal	OFF	
IR1_Index	22.0	
IR2_Cooking_Signal	ON	
IR2_Index	21.6	
VFD_Speed	0	%
Fire1	OFF	
Air_Flow	269.9	CFM
Standard_Air_Flow	269	CFM
Mass_Flow	20	Lb/min
Duct_DP	0.02	IWC
Duct_Temp	72.7	°F
Filter1 Dirty	OFF	
Filter_Alarm_Reset	OFF	
Cooking	ON	
Kitchen_Sched	OFF	
Acknowledge_Alarm	OFF	
Space_Temp	72.0	°F

Display Field	Recommended Value and Action
IR1_Index IR2_Index, etc	<ul style="list-style-type: none"> Appliance OFF - 59 - 80 °F Appliance ON: > 80 °F Power supply off: -220 °F <p>NOTE: if more than 1 IRIS™ sensor, check each IR_Index value. If all values are -220 check that power supply.</p>
Duct_DP	<ul style="list-style-type: none"> Exhaust fan OFF: 0.00 IWC Exhaust fan ON: up to 1 IWC (single unit) Exhaust fan ON: up to 3 IWC (multiple units with common duct)
Duct_Temp	<ul style="list-style-type: none"> Cooking: 50 to 150 °F Not cooking: ambient room temperature

FAQ's (Frequently Asked Questions)

Problem	Probable Cause	Solution
Laser on Alignment Tool does not work	Battery low	Replace battery. Unscrew end of tool, remove the battery and replace with same type.
Exhaust damper blades do not open or close	Loose set screws	Tighten
	In-operable motor	Replace
No suction at hood	VFD tripped	Check for error code, reset
	Surface and duct temperature sensors not activated	Push override button

M.A.R.V.E.L. Parts List

The following is the recommended parts list for proper care and maintenance of the M.A.R.V.E.L. equipment. Parts indicated with a * should be kept readily on hand, the amount depending on the number of hoods in the system.

NOTE: Contact Halton for information on other replacement parts as required

Part	Halton Part Number
Pressure transducer* (for each hood)	18081
Pressure transducer* (for common duct for multiple units only)	18045
Temperature sensor*	18024
IRIS™ sensor*	18037
Actuator* (for balancing damper) (optional)	16012
MC8 Controller (optional)	18035

M.A.R.V.E.L. Parts List

United States

Halton Company
101 Industrial Drive
Scottsville, Kentucky
42164

Tel: 270-237-5600
Toll Free: 800-442-5866

Fax: 270-237-5700

www.haltoncompany.com

Canada

Halton Indoor Climate Systems
1021 Brevik Place
Mississauga, Ontario
L4W 3R7

Tel: 905-624-0301
Toll Free: 800-565-2981

Fax: 905-624-5547

www.haltoncanada.com

HALTON LIMITED WARRANTY

Halton ("Manufacturer"). Warrants only to its direct purchasers and to no others, that all products manufactured by the Manufacturer shall be free from defect in materials and workmanship for a period of twelve (12) months from the date of the original installation and start-up or eighteen (18) months from date of shipment, whichever occurs first. All products sold but not manufactured by Manufacturer will be warranted for a period of twelve (12) months from date of shipment.

For products manufactured by the Manufacturer we agree to pay any reasonable labor costs necessary to repair or replace, at Manufacturers option, defective parts or materials for a period of twelve (12) months from date of original installation and start-up or eighteen (18) months from date of shipment, whichever occurs first. All labor costs subject hereto shall be performed during standard work hours at straight-time rates.

For products sold but not manufactured by the Manufacturer we agree to pay any reasonable labor costs necessary to repair or replace, at Manufacturers option, defective parts or materials for a period of (90) days from date of original installation and start-up or (12) months from date of shipment, whichever occurs first. All labor costs subject hereto shall be performed during standard work hours at straight-time rates.

Purchaser shall pay incurred premium labor charge, including overtime, weekends and holidays. Travel time, service charges, miscellaneous tools, material charges, and labor charges resulting from inaccessibility of equipment will not be paid by Manufacturer.

This **LIMITED WARRANTY SHALL APPLY ONLY** to products that have been installed and maintained in accordance with the installation and Care Instruction Manuals. Purchaser shall be solely responsible for adhering to the instructions and procedures set forth in the said instruction manuals.

This **LIMITED WARRANTY SHALL NOT BE APPLICABLE** to any damage or defect resulting from fire, flood, freezing or any Act of God, abuse, misuse, accident, neglect or failure to adhere to all instructions set forth in the installation and Care Instruction Manuals. Furthermore, this limited warranty shall not apply to any product that has been altered, unless such alteration has been approved in writing by a duly authorized representative of the manufacturer. In no event shall the manufacturer be liable for any loss, expense, personal injury or consequential damage, of any kind or character, as may result from a defect in material, and/or workmanship, however caused.

EXCEPT AS IS EXPRESSLY SET FORTH IN THIS LIMITED WARRANTY, MANUFACTURER MAKES NO WARRANTY OF MARKETABILITY FOR FITNESS OR ANY PARTICULAR PURPOSE. NEITHER DOES MANUFACTURER MAKE ANY WARRANTY, EXPRESSED OR IMPLIED, WITH RESPECT TO PRODUCTS SOLD BY MANUFACTURER OR AS TO THE USE THEREOF.

Halton Company

101 Industrial Drive, Scottsville, 42164 USA
Tel: 270-237-5600 Fax: 270-237-5700
Website address www.haltoncompany.com

Halton Indoor Climate Systems, Ltd.

1021 Brevik Place • Mississauga, ON L4W 3R7 CANADA
Tel: 905-624-0301 Fax: 905-624-5547
Website address www.haltoncanada.com

The logo for Halton, featuring the word "Halton" in a bold, blue, sans-serif font.