

GEF-12A

Grease Exhaust Fan



- **UL and ULC listed for 3" (76mm) Clearance from Combustible Material** - Allows for reduced roof openings.
- **Field Ducting Costs Reduced** - Duct extensions through curb and roof is provided as an integral part of the fan.
- **Discharge Clearance of 40" (1016mm)** - As required by NFPA 96, eliminated discharge ductwork above roof.
- **Electrical Installation Costs Reduced** - An electrical conduit sleeve complete with high temperature wire supplied and installed with a disconnect switch as a complete part of the GEFA fan package. The conduit runs the complete length of the duct and the wire terminates approximately 6" (152mm) below the bottom of the duct stub.
- **Servicing Made Easy** - Access doors to fan housing are completely removable.
- **Fan and Duct Cleaning Made Easy** - The fan drive package section is hinged and pivots to allow access directly to the exhaust duct.
- **High Velocity Verticle Discharge** - Average velocity 3000 FPM (15.24 m/s), as recommended by environmental authorities.

Application

Halton Grease Exhaust Fan provides maximum performance and durability in kitchen hood exhaust applications.



Consultant Specification

Kitchen exhaust fan shall be a Halton GEF series Model _____.

The entire fan housing, cowl and discharge shall be 16 gauge cold rolled steel, continuously welded and liquid tight to NFPA 96 requirements.

The unit shall be complete with a 16 gauge aluminized roof curb shipped separately for field installation.

The exhaust duct collar shall be 1" (25mm) insulated double skin (16 gauge inner skin, 20 gauge outer skin) cold rolled steel, all welded. It shall extend 12" (305mm) minimum below the roof line and have a 1.50" (38mm) flanged connection for welding or bolting to the duct system. The minimum clearance from duct collar to combustible roof opening shall be 3" (76mm) per UL and ULC approvals.

The fan wheel shall be all welded, statically and dynamically balanced at factory, with single inlet and backward inclined blades to provide non-overloading characteristics and minimum noise level. Bearings shall be grease lubricated, heavy duty self-aligning flange type, mounted outside of air stream on an oversized, polished steel shaft.

The unit shall be complete with a smoothly curved inlet venturi, to create a streamline air flow into the fan wheel.

The complete unit shall be factory primed and painted, ready for outside installation.

ELECTRICAL - The fan shall have an electrical safety disconnect switch (supplied wired to the fan motor) and an electrical conduit sleeve that runs the complete length of the duct collar. High temperature wire is provided in the conduit to a point approximately 6" (152mm) below the duct collar.

Adjustable pitch (1 or 2 groove) pulleys shall be provided factory set at proper operating speed for motors up to the 5 H.P. For motors over 5 H.P., fixed pulleys are provided.

APPROVALS - The fan shall be UL and ULC approved as a power roof ventilator for kitchen exhaust systems.

STANDARD COMPONENTS - Units shall be complete with a gravity back draft damper located at the fan discharge.

Optional Equipment

- **Pitched Roof Curb** - Designed to suit slope of roof.
- **Extended Inlet Duct Stub** - is available
- **Side Duct Collar Inlet Extension** - When horizontal exhaust duct connection is required.
- **Single Phase Motors** - Recommended only when three phase is not available.

Installation Notes

Halton's UL and ULC listing can reduce roof opening requirements 3" (76mm) clearance from inlet duct collar to combustible roof opening structure.

Electrical Safety disconnect switch is provided on the fan prewired through a conduit, which extends down with the duct stub.

Standard Voltage 208, 480, or 575 volts, three phase, 60 Hz. WHEN ORDERING, SPECIFY VOLTAGE, PHASE AND FREQUENCY. Other voltages are available on request.

Pre-Shipping Roof curb can be pre-shipped separately, when required.

AMCA Drive Loss Chart

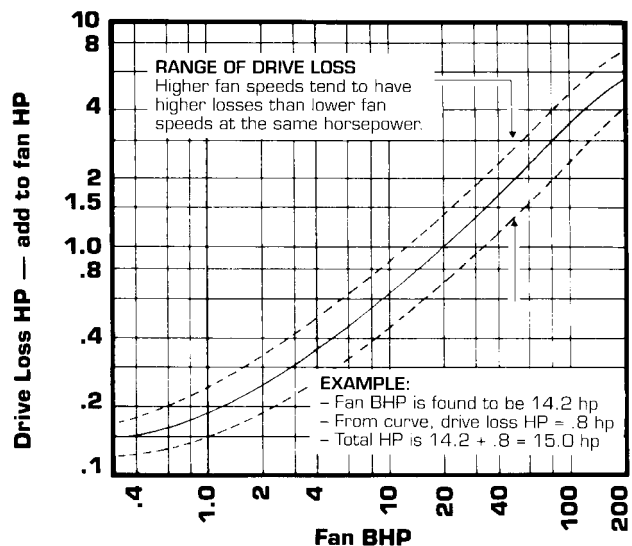

Reprinted from AMCA Publication 203, Field Performance Measurement of Fan Systems, with the express written permission for the Air Movement and Control Association, Inc., 30 West University Drive, Arlington Heights, IL 60004-1983, U.S.A.

Dimension: $\frac{\text{Inches}}{\text{mm}}$

20/GEF-12A/XXXX/0107/EN

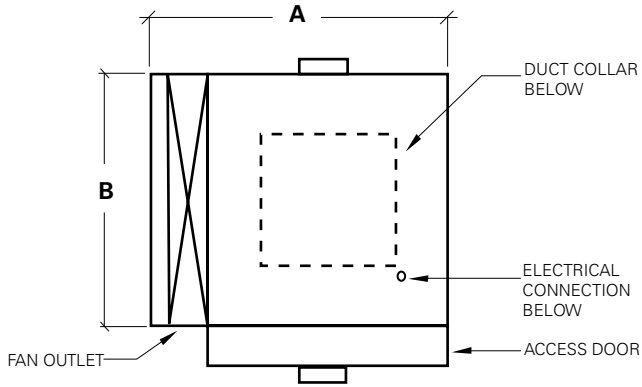

TOP VIEW

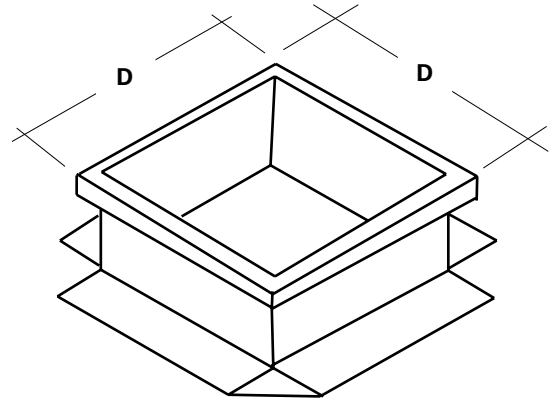

ROOF CURB DETAIL

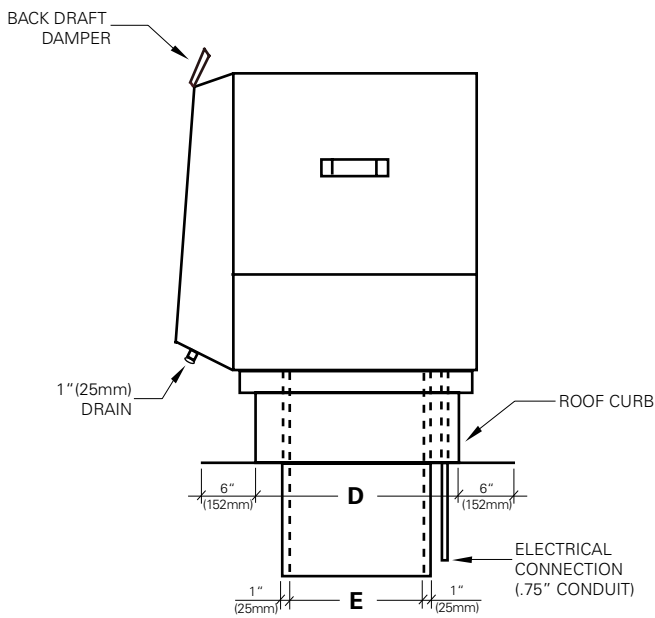

FRONT VIEW

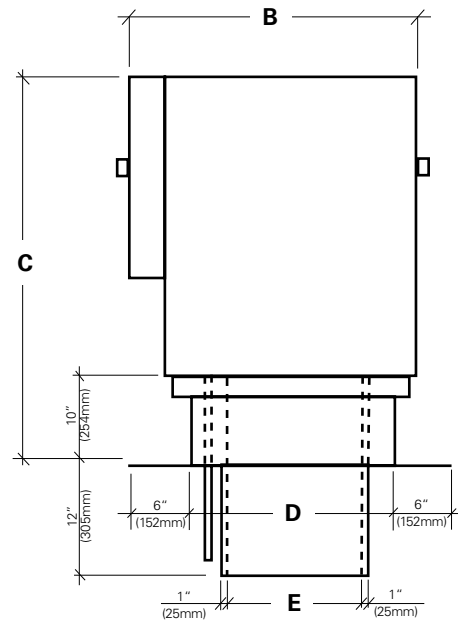

SIDE VIEW

MODEL NUMBER	A		B		C		ROOF OPENING D		E		AIR RANGE		MOTOR SIZE		WEIGHTS			
	in.	mm	in.	mm	in.	mm	in.	mm	in.	mm	cfm	m ³ /s	HP	kW	lbs.	kg.	lbs.	kg
GEF-12A	32.25	819	27.00	686	42.25	1073	21.50	546	14.50	368	800	.38	.50	.37	490	223	395	180
											2200	1.04	2	1.49				

Fan Performance Charts

GEF-12A - Fan Wheel Diameter 12.25" (311mm)

Outlet Area .59 Sq. Ft. (.05 Sq. m)

0.50" W.G. / .12kPa

AIR VOLUME		OUTLET VELOCITY		TOTAL STATIC PRESSURE 0.50" W.G. / .12kPa		
CFM	m ³ /s	FPM	m/s	RPM	BHP	
					HP	kW
800	.38	1026	5.21	1221	.17	.13
1000	.47	1282	6.51	1404	.25	.19
1200	.57	1538	7.81	1597	.37	.28
1400	.66	1795	9.12	1799	.51	.38
1600	.76	2051	10.43	2007	.71	.53
1800	.85	2308	11.73	2219	.95	.71
2000	.94	2564	13.03	2435	1.24	.93
2200	1.04	2821	14.33	2652	1.60	1.19

0.75" W.G. / .19kPa

AIR VOLUME		OUTLET VELOCITY		TOTAL STATIC PRESSURE 0.75" W.G. / .19kPa		
CFM	m ³ /s	FPM	m/s	RPM	BHP	
					HP	kW
800	.38	1026	5.21	1343	.22	.16
1000	.47	1282	6.51	1513	.32	.24
1200	.57	1538	7.81	1696	.45	.34
1400	.66	1795	9.12	1888	.61	.45
1600	.76	2051	10.43	2087	.81	.60
1800	.85	2308	11.73	2291	1.06	.79
2000	.94	2564	13.03	2499	1.36	1.01
2200	1.04	2821	14.33	2713	1.73	1.29

1.00" W.G. / .25kPa

AIR VOLUME		OUTLET VELOCITY		TOTAL STATIC PRESSURE 1.00" W.G. / .25kPa		
CFM	m ³ /s	FPM	m/s	RPM	BHP	
					HP	kW
800	.38	1026	5.21	1457	.28	.21
1000	.47	1282	6.51	1613	.39	.29
1200	.57	1538	7.81	1788	.52	.39
1400	.66	1795	9.12	1972	.70	.52
1600	.76	2051	10.43	2164	.91	.68
1800	.85	2308	11.73	2362	1.18	.88
2000	.94	2564	13.03	2565	1.49	1.11
2200	1.04	2821	14.33	2773	1.87	1.39

1.25" W.G. / .31kPa

AIR VOLUME		OUTLET VELOCITY		TOTAL STATIC PRESSURE 1.25" W.G. / .31kPa		
CFM	m ³ /s	FPM	m/s	RPM	BHP	
					HP	kW
800	.38	1026	5.21	1568	.35	.26
1000	.47	1282	6.51	1708	.46	.34
1200	.57	1538	7.81	1874	.61	.46
1400	.66	1795	9.12	2051	.79	.59
1600	.76	2051	10.43	2237	1.02	.76
1800	.85	2308	11.73	2430	1.29	.96
2000	.94	2564	13.03	2629	1.62	1.21
2200	1.04	2821	14.33	-	-	-

1.50" W.G. / .37kPa

AIR VOLUME		OUTLET VELOCITY		TOTAL STATIC PRESSURE 1.50" W.G. / .37kPa		
CFM	m ³ /s	FPM	m/s	RPM	BHP	
					HP	kW
800	.38	1026	5.21	1683	.43	.32
1000	.47	1282	6.51	1799	.53	.40
1200	.57	1538	7.81	1956	.69	.51
1400	.66	1795	9.12	2127	.88	.66
1600	.76	2051	10.43	2309	1.13	.84
1800	.85	2308	11.73	2496	1.41	1.05
2000	.94	2564	13.03	2689	1.75	1.31
2200	1.04	2821	14.33	-	-	-

1.75" W.G. / .43kPa

AIR VOLUME		OUTLET VELOCITY		TOTAL STATIC PRESSURE 1.75" W.G. / .43kPa		
CFM	m ³ /s	FPM	m/s	RPM	BHP	
					HP	kW
800	.38	1026	5.21	-	-	-
1000	.47	1282	6.51	1888	.61	.46
1200	.57	1538	7.81	2034	.77	.57
1400	.66	1795	9.12	2199	.98	.73
1600	.76	2051	10.43	2376	1.23	.92
1800	.85	2308	11.73	2560	1.53	1.14
2000	.94	2564	13.03	2750	1.88	-
2200	1.04	2821	14.33	-	-	-

2.00" W.G. / .50kPa

AIR VOLUME		OUTLET VELOCITY		TOTAL STATIC PRESSURE 2.00" W.G. / .50kPa		
CFM	m ³ /s	FPM	m/s	RPM	BHP	
					HP	kW
800	.38	1026	5.21	-	-	-
1000	.47	1282	6.51	1977	.70	.52
1200	.57	1538	7.81	2110	.86	.64
1400	.66	1795	9.12	2270	1.08	.81
1600	.76	2051	10.43	2441	1.34	1.00
1800	.85	2308	11.73	2621	1.65	1.23
2000	.94	2564	13.03	-	-	-
2200	1.04	2821	14.33	-	-	-

2.25" W.G. / .56kPa

AIR VOLUME		OUTLET VELOCITY		TOTAL STATIC PRESSURE 2.25" W.G. / .56kPa		
CFM	m ³ /s	FPM	m/s	RPM	BHP	
					HP	kW
800	.38	1026	5.21	-	-	-
1000	.47	1282	6.51	2069	.79	.59
1200	.57	1538	7.81	2186	.96	.72
1400	.66	1795	9.12	2338	1.17	.87
1600	.76	2051	10.43	2505	1.47	1.10
1800	.85	2308	11.73	2682	1.77	1.32
2000	.94	2564	13.03	-	-	-
2200	1.04	2821	14.33	-	-	-

2.50" W.G. / .62kPa

AIR VOLUME		OUTLET VELOCITY		TOTAL STATIC PRESSURE 2.50" W.G. / .62kPa		
CFM	m ³ /s	FPM	m/s	RPM	BHP	
					HP	kW
800	.38	1026	5.21	-	-	-
1000	.47	1282	6.51	-	-	-
1200	.57	1538	7.81	2260	1.05	.78
1400	.66	1795	9.12	2404	1.28	.95
1600	.76	2051	10.43	2568	1.56	1.16
1800	.85	2308	11.73	2740	1.89	1.41
2000	.94	2564	13.03	-	-	-
2200	1.04	2821	14.33	-	-	-

Continuous product improvement is a Halton policy, therefore specifications and designs are subject to change without notice.