

Operators Manual

Installation, Operation and Maintenance Instructions

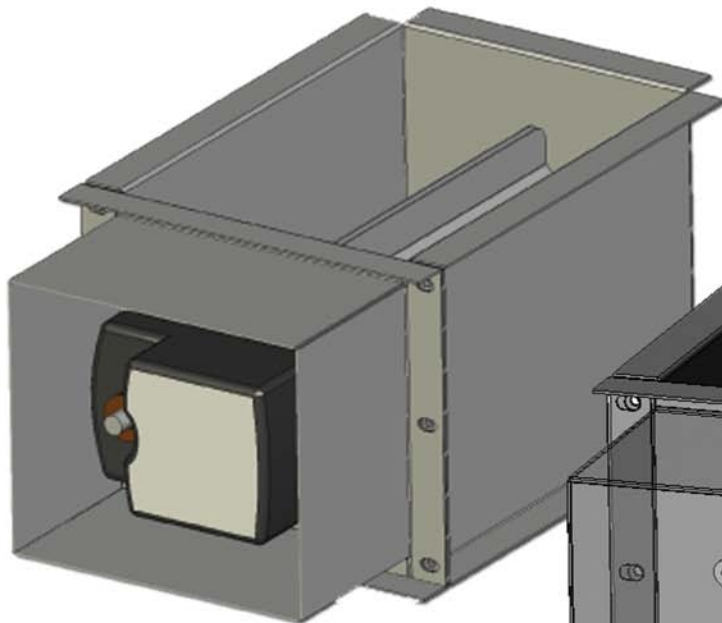

**Automated Balancing
Damper - ABD**

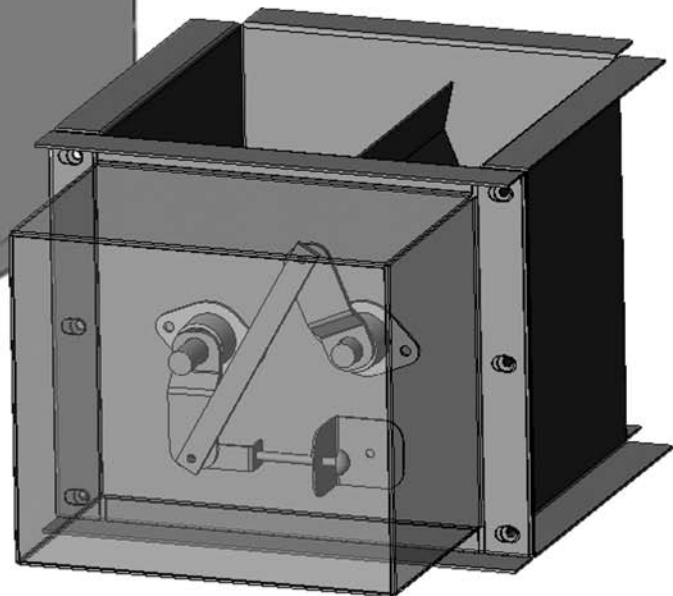

**Manual Balancing Damper
- MBD**



Exhaust Volume Dampers
Model: ABD & MBD

Halton

INSTALLATION INSTRUCTIONS

Carefully unpack the unit. Units are to be installed vertically, check engineered drawings or job specifics on installation. Height requirements are shown on **Figure 1**.

Figure 2 shows a typical installation. Set the unit on top of the exhaust collar of the kitchen hood. The Balancing Damper has a 1" flange around the perimeter that should match up with the exhaust collar's 1" flange. These flanges are to be continuously welded together. The 1" flange on the opposite end of the Balancing Damper will mate up with a 1" flange on the exhaust duct. These flanges are to be continuously welded together. Note that in the closed position the peak of the closed vanes point upward (into the exhaust duct). **See Figure 3**. Ensure that vanes are facing upwards for proper installation. **See Figure 4**.

MAINTENANCE

The inside of the damper is accessible through the exhaust plenum of the hood. Clean as necessary.

ADJUSTMENT

The automatic damper (ABD) will be operated by the damper controller. No adjustment is required at the time of installation.

The manual damper (MBD) can be adjusted by first removing the cover over the adjustment mechanism (**Fig 3 Item "A"**). Loosen the 10-24 lock nut (**Fig 3 Item "B"**) counterclockwise using a 3/8" wrench and then adjust the thumbscrew (**Fig 3 Item "C"**) accordingly. By turning the thumbscrew "A" clockwise the damper is opened and by turning it counterclockwise the damper is closed. Tighten the 10-24 lock nut "B" against the bracket after adjustment is complete.

Figure 1

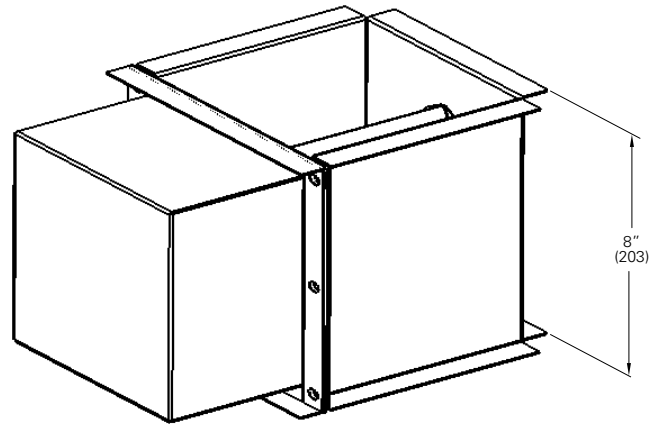

Figure 2

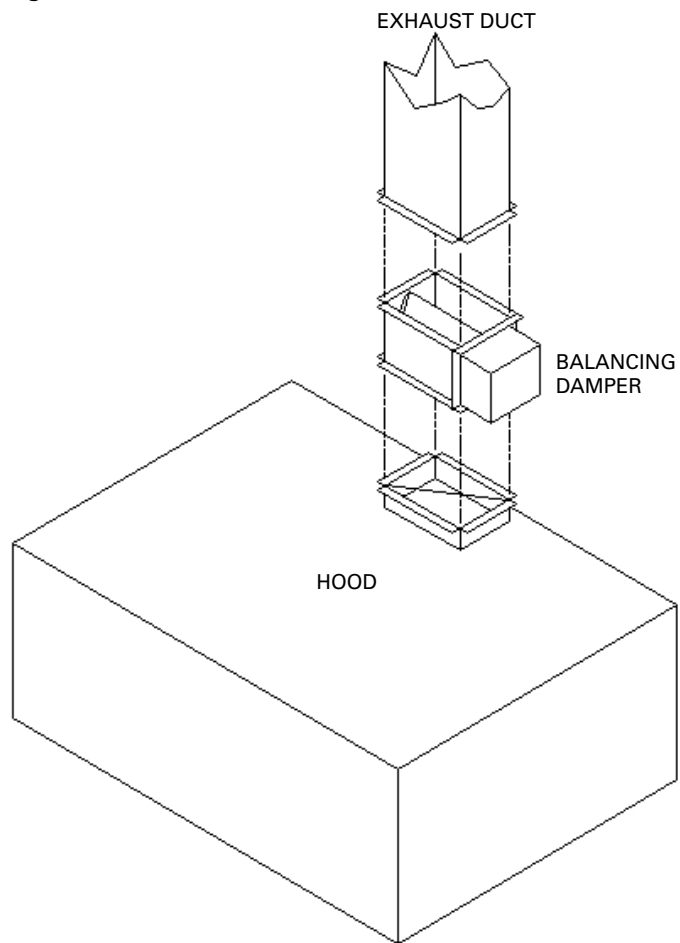

Figure 3

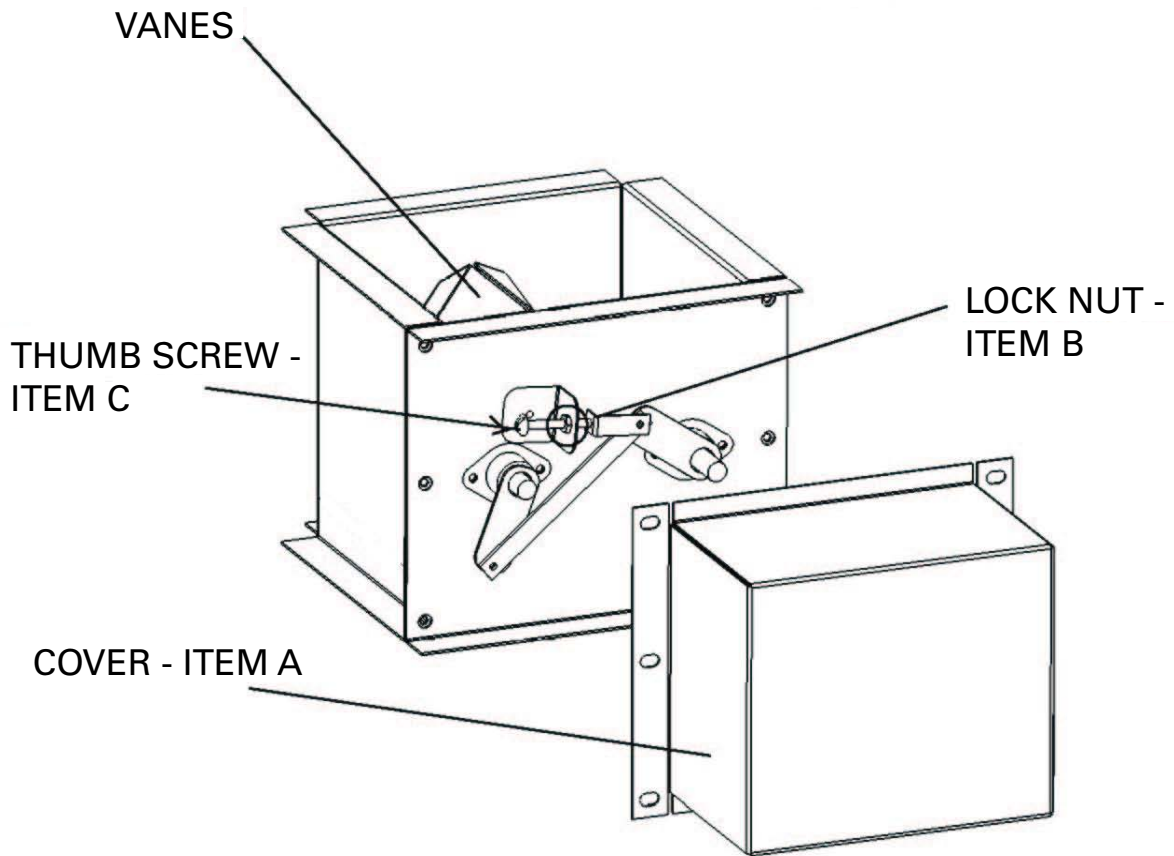
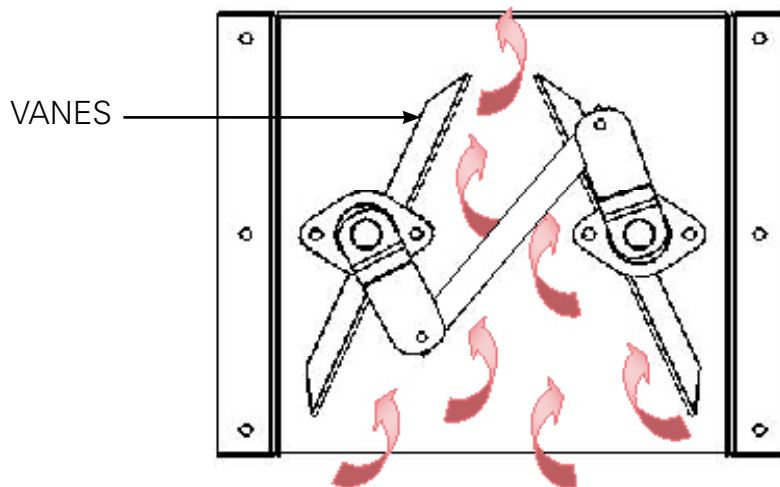

Figure 4



Ensure that vanes are facing upwards for proper installation.
Cross section showing air moving through damper.

HALTON LIMITED WARRANTY

Halton ("Manufacturer"). Warrants only to its direct purchasers and to no others, that all products manufactured by the Manufacturer shall be free from defect in materials and workmanship for a period of twelve (12) months from the date of the original installation and start-up or eighteen (18) months from date of shipment, whichever occurs first. All products sold but not manufactured by Manufacturer will be warranted for a period of twelve (12) months from date of shipment.

For products manufactured by the Manufacturer we agree to pay any reasonable labor costs necessary to repair or replace, at Manufacturers option, defective parts or materials for a period of twelve (12) months from date of original installation and start-up or eighteen (18) months from date of shipment, whichever occurs first. All labor costs subject hereto shall be performed during standard work hours at straight-time rates.

For products sold but not manufactured by the Manufacturer we agree to pay any reasonable labor costs necessary to repair or replace, at Manufacturers option, defective parts or materials for a period of (90) days from date of original installation and start-up or (12) months from date of shipment, whichever occurs first. All labor costs subject hereto shall be performed during standard work hours at straight-time rates.

Purchaser shall pay incurred premium labor charge, including overtime, weekends and holidays. Travel time, service charges, miscellaneous tools, material charges, and labor charges resulting from inaccessibility of equipment will not be paid by Manufacturer.

This **LIMITED WARRANTY SHALL APPLY ONLY** to products that have been installed and maintained in accordance with the installation and Care Instruction Manuals. Purchaser shall be solely responsible for adhering to the instructions and procedures set forth in the said instruction manuals.

This **LIMITED WARRANTY SHALL NOT BE APPLICABLE** to any damage or defect resulting from fire, flood, freezing or any Act of God, abuse, misuse, accident, neglect or failure to adhere to all instructions set forth in the installation and Care Instruction Manuals. Furthermore, this limited warranty shall not apply to any product that has been altered, unless such alteration has been approved in writing by a duly authorized representative of the manufacturer. In no event shall the manufacturer be liable for any loss, expense, personal injury or consequential damage, of any kind or character, as may result from a defect in material, and/or workmanship, however caused.

EXCEPT AS IS EXPRESSLY SET FORTH IN THIS LIMITED WARRANTY, MANUFACTURER MAKES NO WARRANTY OF MARKETABILITY FOR FITNESS OR ANY PARTICULAR PURPOSE. NEITHER DOES MANUFACTURER MAKE ANY WARRANTY, EXPRESSED OR IMPLIED, WITH RESPECT TO PRODUCTS SOLD BY MANUFACTURER OR AS TO THE USE THEREOF.